

'QUIPTRON' SKIMMERS

REPLACEMENT PARTS

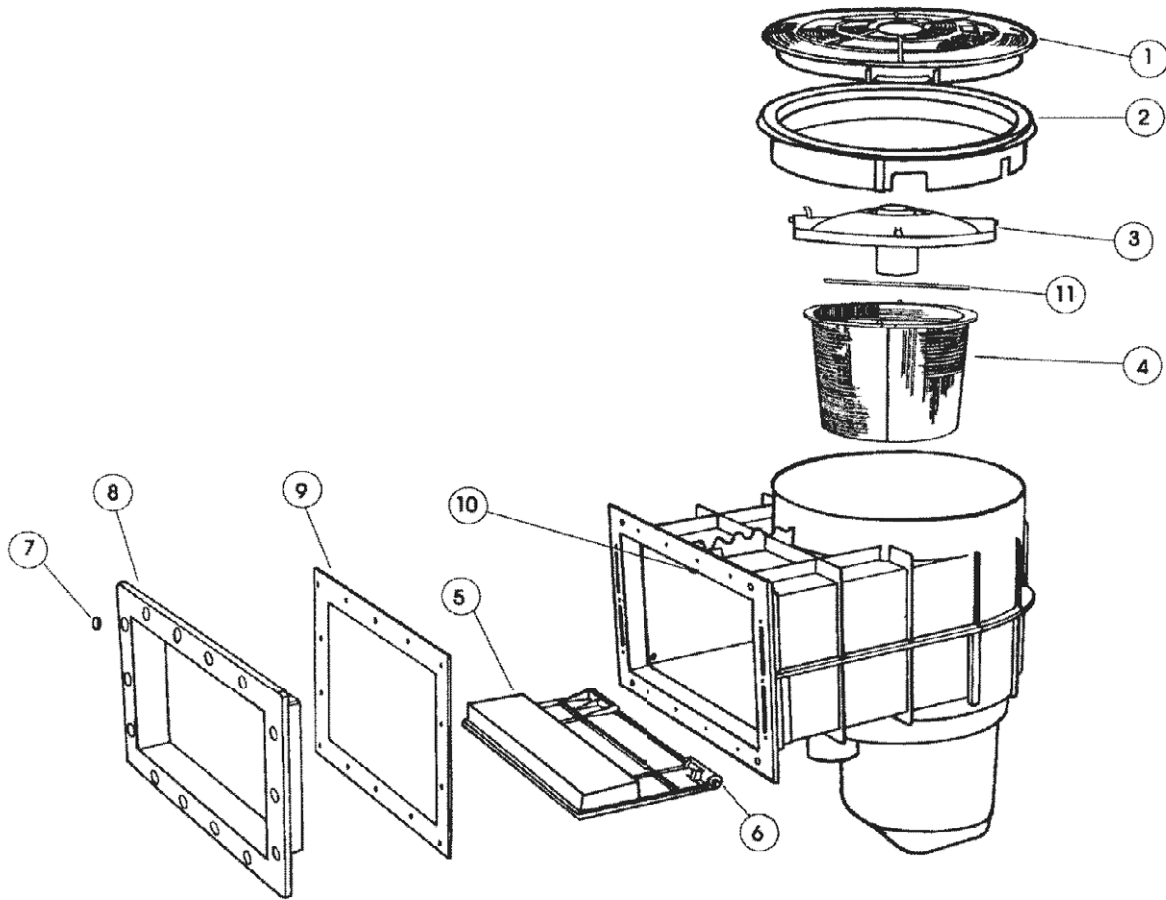

Drawing shows typical assembly, please note actual parts may vary in appearance

Item	Part No.	Description
'QUIPTRON' SKIMMERS		
1	5160900	DECK LID Skimmer (WHITE)
1	5160901	DECK LID Skimmer (BEIGE)
1	5160902	DECK LID Skimmer (BROWN)
2	5160800	DRESS RING SK950 Skmr (WHITE)
2	5160801	DRESS RING SK950 Skmr (BEIGE)
2	5160802	DRESS RING SK950 Skmr (BROWN)
3	5315100	CONTROL PLATE ASSY QUIPTRON Skimmer
4	5315200	Leaf Basket for 'Quiptron' Skimmer
5	5315300	WEIR DOOR QUIPTRON Skimmer
6	5315400	LATCH ASSY. (Pack/2) QUIPTRON
7&8	5316400	QUIPTRON SKIMMER ESCUTCHEON PLATE AND PLUGS
9	5315800	GASKET QUIPTRON Skimmer
NOT SHOWN		
	5315900	QUIPTRON SKIMMER ESCUTCHEON PLATE SCREWS
	5316500	EXTENSION THROAT QPTRN Skimmer