

Owner's Manual



ONGA[®]



Spa Blower

Installation & operation instructions

Should the installer or owner be unfamiliar with the correct installation or operation of this type of equipment you should contact the distributor/manufacture for the correct advice before proceeding with the installation or operation of this product.

These instructions act as a guide only and do not cover every contingency. People not familiar with pool filtration and pumping equipment should seek advice from an authorised Onga stockist.

SPA BLOWER INSTALLATION AND OPERATION INSTRUCTIONS

1. Run 50mm PVC pipe line from the spa pool manifold outlet to spa blower position (maximum operating distance 12 metres), ensuring that the 50mm pipe line has a minimum fall of 1:10 back to the spa, this will allow the pipe line to have minimum water lying in the pipe (refer diagram 1).

2. Run your vertical 50mm pvc pipe a minimum of 600mm above the spa pools maximum water level.

Allow 24 hours for glue vapours to dissipate from the pipe work before mounting spa blower onto pipe (failure to do so may cause damage to the spa blower, pipe work and void warranty). Place the blower on the pipe and tighten the stain-less steel mounting screw located on the check-valve (refer diagram 1).

DO NOT GLUE THE SPA BLOWER TO THE 50MM PIPE.

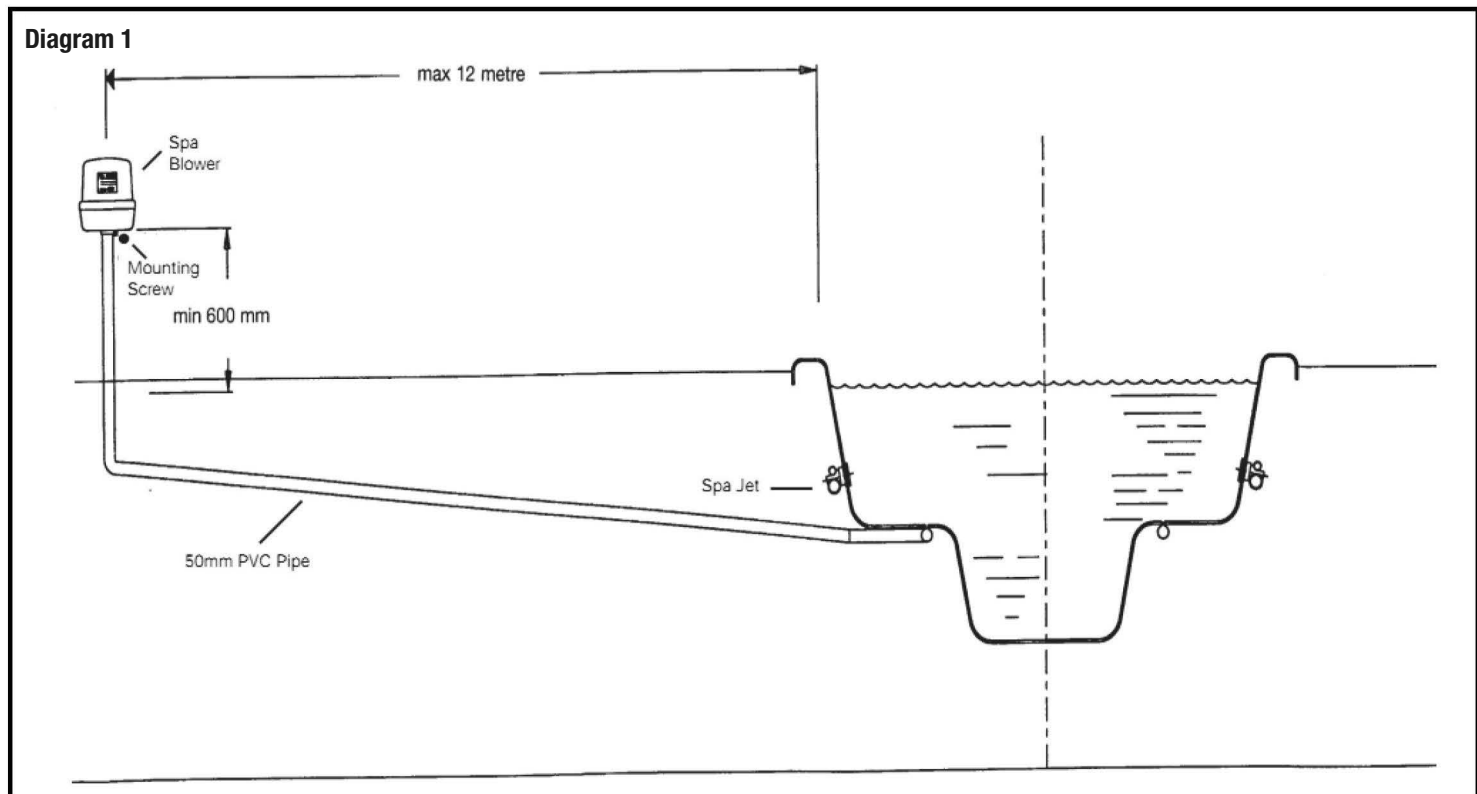

3. If the spa blower is to be mounted below water level, extend the air loop 600mm above the maximum water level and return back to the spa blower, drill a bleed hole after loop to remove any condensation (refer diagram 2). DO NOT create a water trap in the blower supply pipe (refer diagram 3), as the water lying in the pipe will create additional back pressure on the spa blower. Mount the spa blower as instructed above (2).

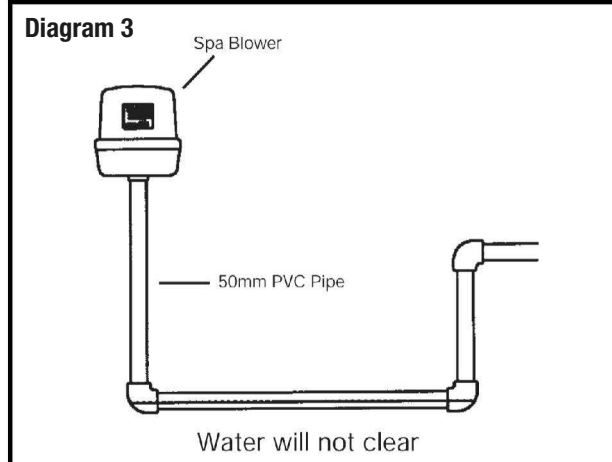
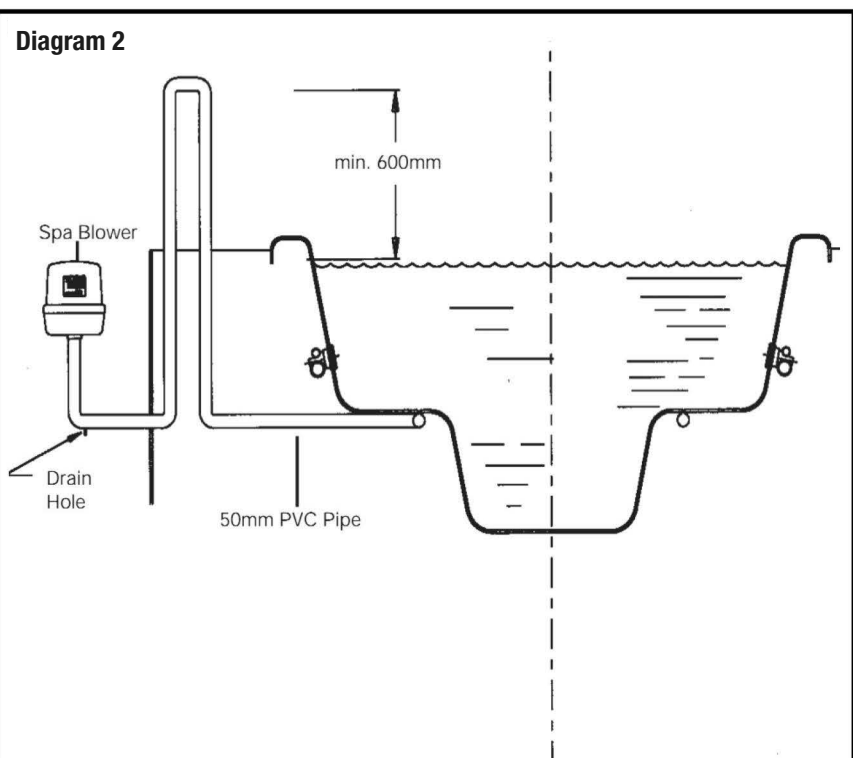

4. If the spa blower is to be used for additional spa jet venturi, connect the supply line into the air supply line of the spa jet using a tee, then follow the instructions of 1 & 2 and refer to (diagram 4)

5. Spa blower MUST be mounted in a vertical position only, with the discharge downwards (refer diagram 1, 2, & 4).

6. If a air switch or three speed option is being fitted a roll of air tube is supplied, enclose the air line in conduit for mechanical protection, place one end of the tube onto the nipple of the air button fitted on the spa pool, place the other end of the air line onto the spa blower, the air nipple is located on the under side of the spa blower.

7. Place the spa blower 10 amp lead into a 240 volt 50Hz designated power point.

8. Minimal Air Hole Specifications

36 x 6 mm Diameter Holes
18 x 8 mm Diameter Holes

(refer diagram 5)

IMPORTANT INSTALLER PLEASE NOTE

The diameter and quantity of air holes listed above are based on a spa pool air manifold maximum water submergence depth of:

- (1) 600mm (seat/recliner manifold)
- (2) 800mm (footwell manifold)

If the spa depth/manifold dimensions vary from above please contact the Pentair Water office in your state for advice and verification, failure to comply may damage the equipment and void the product warranty.

OPERATION OF YOUR SPA BLOWER

1. Switch power on, your spa blower will start.

(a) If your spa blower has been plugged into another controller it may not start until the air button or some other form of switching has been pressed. (Check with your installer).

(b) Air Switch Blower Operation

Simply press the air button located on the spa and your spa blower will start on high speed, press your button again and this will turn the spa blower off.

WARNING This appliance is not intended for use by persons (including children) with reduced physical, sensory or mental capabilities, or lack of experience and knowledge, unless they have been given supervision or instruction concerning the use of the appliance by a person responsible for their safety.

Children should be supervised to ensure they do not play with the appliance.

If the supply cord is damaged, the equipment should be discarded or scrapped.

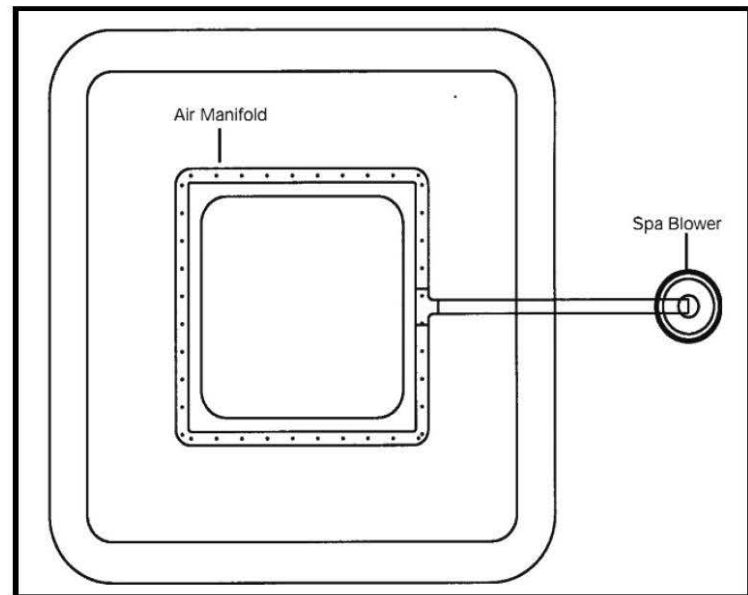
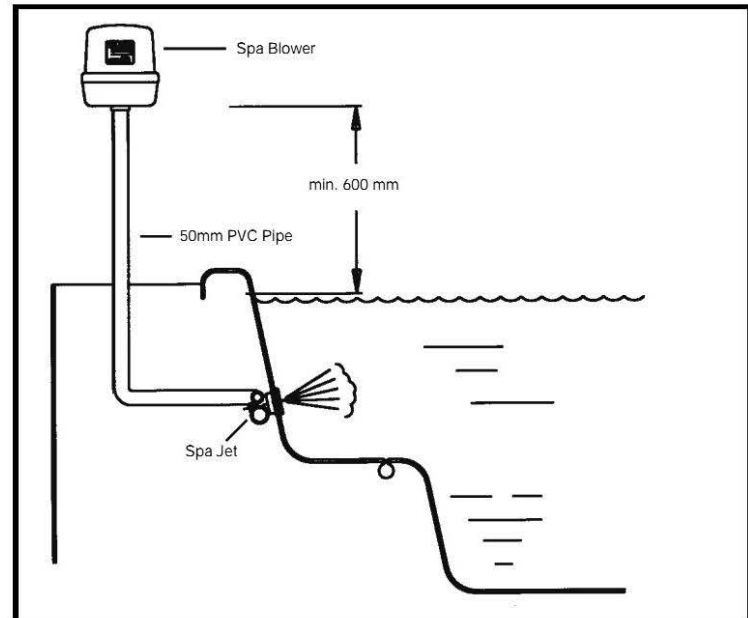

No part of this appliance is to be located above the spa pool and must be inaccessible to a person in the spa pool. All parts must be fixed so they cannot fall into the spa pool.

The appliance should be supplied through a residual current device (RCD) having a rated current not exceeding 30mA.

TROUBLE SHOOTING GUIDE

SYMPTOM	REMEDY
Spa blower will not start.	Check power point is switched on and spa blower is plugged in. Check Fuses.
	Check that air line is connected from the air button to the spa blower.
	Check that the air line is not kinked. If kinks are visible, remove them otherwise this will stop the pulse of air that operates the micro switch inside the spa blower.
	Check micro switch operation. Push air button and a faint click should be heard at the spa blower, if no click is heard check all connections if they are all OK and spa blower still doesn't start, remove spa blower and take it to the nearest Pentair Water service agent.
Spa blower is making a grinding noise when operating.	Bearings/brushes may need replacing.
Spa blower makes a noise when stopping.	This is only the check-valve operating correctly.
Spa blower operates then stops (cutting out on thermal overload),	Could be caused by blockage or insufficient air holes, check installation of the spa blower pipe work, ensure that it has been installed to the specifications, if incorrect call installer. If all plumbing is correct remove the spa blower and take it to your nearest Pentair Water service agent.

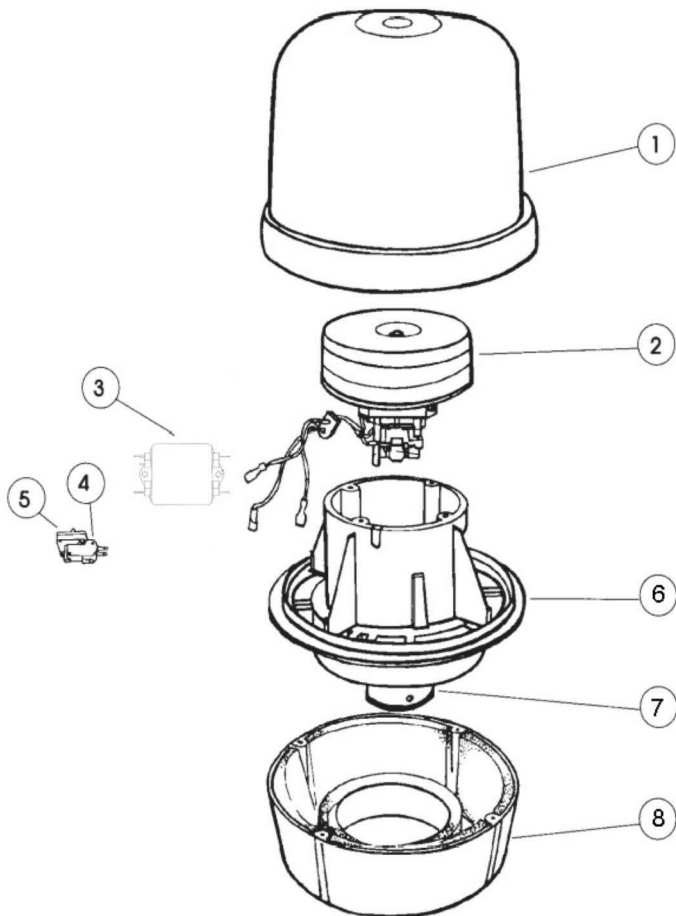

Spa Blower		
1	Cover	1100508
2	Motor (1200 Watt)	707431
3	EMC Filter (units prior to 2016)	707425
4	Micro Switch	N/A
5	Air Switch Holder	N/A
	Air Sensor Assembly (Includes Items 4&5)	302470
6	Motor Housing	N/A
7	Checkvalve (40mm-50mm)	N/A
	Motor Housing and Check -Valve Assembly (Includes Items 6&7)	707435
8	Cowl	707497

IMPORTANT

Please attach your sales invoice/docket here as proof of purchase should warranty service be required.

Please do not return Warranty Form to Pentair Australia - please retain for your records.

Purchased From

Purchase Date..... Serial No..... Model No.....



Head Office

Pentair AU/NZ: 1-21 Monash Drive,
Dandenong South, Vic 3175

Australia

National Customer Service: Phone: 1300 137 344
Fax: 1800 006 688
National Dealer Locator: Phone: 1800 664 266
Email: au.sales@pentair.com
Web: www.pentair.com.au

International

Phone: +61 3 9709 5800
Fax: +61 3 9709 5888

© Information contained here-in remains the property of Pentair Water Pty Ltd. Any reproduction, display, publication, modification or distribution is strictly prohibited without the prior written permission of Pentair Water Pty Ltd.

Disclaimer: Every endeavour has been made to publish the correct details in this data sheet. No responsibility will be taken for errors, omissions or changes in product specifications. Pentair Water reserves the right to change specifications

L300220 B0920