

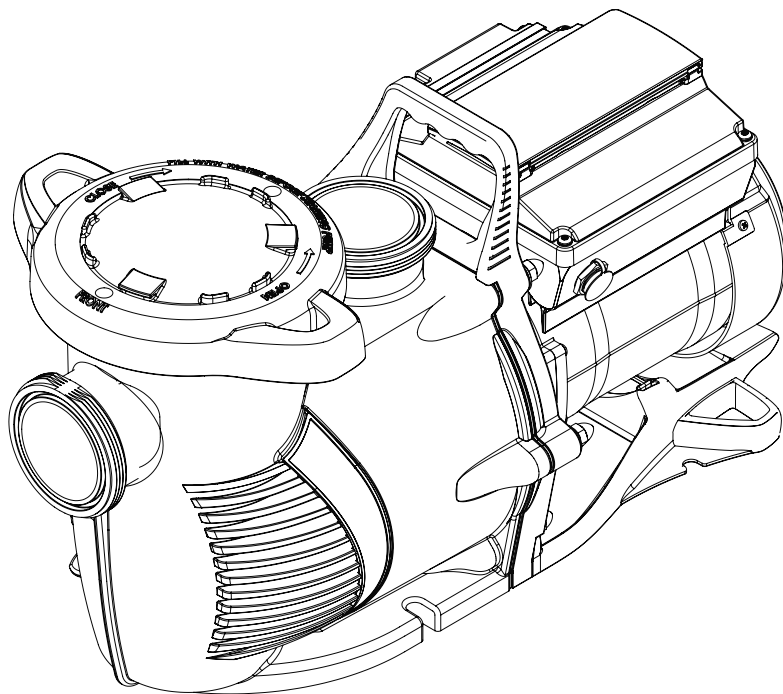

STA-RITE

INTELLIFLOXF[®] AND INTELLIPROXF[®] VARIABLE SPEED ULTRA ENERGY EFFICIENT PUMP



INSTALLATION AND USER'S GUIDE

IMPORTANT SAFETY INSTRUCTIONS
READ AND FOLLOW ALL INSTRUCTIONS
SAVE THESE INSTRUCTIONS



CUSTOMER SERVICE / TECHNICAL SUPPORT

If you have questions about ordering Pentair Water Pool and Spa replacement parts, and pool products, please contact:

Customer Service and Technical Support, USA
(8 A.M. to 4:30 P.M. — Eastern/Pacific Times)

Phone: (800) 831-7133

Fax: (800) 284-4151

Web site

Visit www.pentairpool.com or www.staritepool.com for information about Pentair products.

Sanford, North Carolina (8 A.M. to 4:30 P.M. ET)

Phone: (919) 566-8000

Fax: (919) 566-8920

Moorpark, California (8 A.M. to 4:30 P.M. PT)

Phone: (805) 553-5000 (Ext. 5591)

Fax: (805) 553-5515

TABLE OF CONTENTS

Important Pump Warning and Safety Instructions	ii	Features	13
Pump Overview	1	Quick Clean/Only High Speed Override Feature	13
Pump Components and Features	1	Time Out	13
Union Adapter Installation	1	Priming	13
Installation	2	Setting Priming Features	14
Location	2	Disabling Priming with an	15
Piping, Fittings, and Valves	2	Automation System	15
Electrical Wiring Installation	3	Anti Freeze	16
Operating the Pump	4	Connecting to an Automation System	17
Priming the Pump	4	External Control with IntelliComm	17
Using the Operator Control Panel	5	Connecting to EasyTouch and	17
Starting and Stopping the Pump	6	IntelliTouch Systems	19
Adjust and Save a Pump Speed	6	Connecting to SunTouch Systems	19
Pump Operating Modes	6	Maintenance	20
Control Panel Language	6	Pump Strainer Basket	20
Operator Control Panel Menu Guide	7	Cleaning the Pump Strainer Basket	20
Pump Settings	8	Winterizing	20
Pump Address	8	Servicing	21
Set Time & AM/PM or 24 Hour Clock	8	Motor Service	21
Set Temperature Unit	8	Pump Disassembly	21
Screen Contrast Level	8	Mechanical Seal	21
Set Min/Max Speeds	9	Pump Reassembly/Seal Replacement	22
Password Protection	9	Drive Assembly Removal and Installation	23
Setting & Entering Password	10	Alerts and Warnings	23
Setting Speeds 1-8	11	Troubleshooting	24
Pump Operating Modes	11	Problems and Corrective Actions	24
Setting Speeds in Manual or Egg Timer Mode	11	Replacement Parts	26
(Speeds 1-4 only)	11	Illustrated Parts List	26
Setting Speeds 1-8 in Schedule Mode	12	Pump Performance Curves	27
External Control	12	Pump Dimensions	27
		Control Panel Quick Reference Guide	28

Compatible with IntelliComm® Communication Center and EasyTouch®, IntelliTouch® and SunTouch® Control Systems. Quick Reference Guide for the Operator Control Panel on page 28.

IMPORTANT PUMP WARNING AND SAFETY INSTRUCTIONS



IMPORTANT NOTICE

This guide provides installation and operation instructions for the IntelliFloXF® and IntelliProXF® Variable Speed Pumps. Consult Pentair with any questions regarding this equipment.

Attention Installer: This guide contains important information about the installation, operation and safe use of this product. This information should be given to the owner and/or operator of this equipment after installation or left on or near the pump.

Attention User: This manual contains important information that will help you in operating and maintaining this product. Please retain it for future reference.

READ AND FOLLOW ALL INSTRUCTIONS SAVE THESE INSTRUCTIONS



This is the safety alert symbol. When you see this symbol on your system or in this manual, look for one of the following signal words and be alert to the potential for personal injury.

DANGER

Warns about hazards that can cause death, serious personal injury, or major property damage if ignored.

WARNING

Warns about hazards that may cause death, serious personal injury, or major property damage if ignored.

CAUTION

Warns about hazards that may or can cause minor personal injury or property damage if ignored.

NOTE indicates special instructions not related to hazards.

Carefully read and follow all safety instructions in this manual and on equipment. Keep safety labels in good condition; replace if missing or damaged.

When installing and using this electrical equipment, basic safety precautions should always be followed, include the following:

WARNING Do not permit children to use this product.

WARNING **RISK OF ELECTRICAL SHOCK.** Connect only to a branch circuit protected by a ground-fault circuit-interrupter (GFCI). Contact a qualified electrician if you cannot verify that the circuit is protected by a GFCI.

WARNING This unit must be connected only to a supply circuit that is protected by a ground-fault circuit-interrupter (GFCI). Such a GFCI should be provided by the installer and should be tested on a routine basis. To test the GFCI, push the test button. The GFCI should interrupt power. Push the reset button. Power should be restored. If the GFCI fails to operate in this manner, the GFCI is defective. If the GFCI interrupts power to the pump without the test button being pushed, a ground current is flowing, indicating the possibility of an electric shock. Do not use this pump. Disconnect the pump and have the problem corrected by a qualified service representative before using.

CAUTION This pump is for use with permanent swimming pools and may also be used with hot tubs and spas if so marked. Do not use with storable pools. A permanently-installed pool is constructed in or on the ground or in a building such that it cannot be readily disassembled for storage. A storable pool is constructed so that it is capable of being readily disassembled for storage and reassembled to its original integrity.

General Warnings

- Never open the inside of the drive motor enclosure. There is a capacitor bank that holds a 230 VAC charge even when there is no power to the unit.
- The pump is not submersible.
- The pump is capable of high flow rates; use caution when installing and programming to limit pumps performance potential with old or questionable equipment.
- Code requirements for the electrical connection differ from state to state. Install equipment in accordance with the National Electrical Code and all applicable local codes and ordinances.
- Before servicing the pump; switch OFF power to the pump by disconnecting the main circuit to the pump.
- This appliance is not intended for use by persons (including children) of reduced physical, sensory or mental capabilities, or lack of experience and knowledge, unless they have been given supervision or instruction concerning the use of the appliance by a person responsible for their safety.

DANGER FAILURE TO FOLLOW ALL INSTRUCTIONS AND WARNINGS CAN RESULT IN SERIOUS BODILY INJURY OR DEATH. **THIS PUMP SHOULD BE INSTALLED AND SERVICED ONLY BY A QUALIFIED POOL SERVICE PROFESSIONAL. INSTALLERS, POOL OPERATORS AND OWNERS MUST READ THESE WARNINGS AND ALL INSTRUCTIONS IN THE OWNER'S MANUAL BEFORE USING THIS PUMP. THESE WARNINGS AND THE OWNER'S MANUAL MUST BE LEFT WITH THE POOL OWNER.**

DANGER SUCTION ENTRAPMENT HAZARD: STAY OFF THE MAIN DRAIN AND AWAY FROM ALL SUCTION OUTLETS!



THIS PUMP PRODUCES HIGH LEVELS OF SUCTION AND CREATES A STRONG VACUUM AT THE MAIN DRAIN AT THE BOTTOM OF THE BODY OF WATER. THIS SUCTION IS SO STRONG THAT IT CAN TRAP ADULTS OR CHILDREN UNDER WATER IF THEY COME IN CLOSE PROXIMITY TO A DRAIN OR A LOOSE OR BROKEN DRAIN COVER OR GRATE.

THE USE OF UNAPPROVED COVERS OR ALLOWING USE OF THE POOL OR SPA WHEN COVERS ARE MISSING, CRACKED OR BROKEN CAN RESULT IN BODY OR LIMB ENTRAPMENT, HAIR ENTANGLEMENT, BODY ENTRAPMENT, EVISCERATION AND/OR DEATH.

The suction at a drain or outlet can cause:

Limb Entrapment: When a limb is sucked or inserted into an opening resulting in a mechanical bind or swelling. This hazard is present when a drain cover is missing, broken, loose, cracked or not properly secured.

Hair Entanglement: When the hair tangles or knots in the drain cover, trapping the swimmer underwater. This hazard is present when the flow rating of the cover is too small for the pump or pumps.

Body Entrapment: When a portion of the body is held against the drain cover trapping the swimmer underwater. This hazard is present when the drain cover is missing, broken or the cover flow rating is not high enough for the pump or pumps.

Evisceration/Disembowelment: When a person sits on an open pool (particularly a child wading pool) or spa outlet and suction is applied directly to the intestines, causing severe intestinal damage. This hazard is present when the drain cover is missing, loose, cracked, or not properly secured.

IMPORTANT PUMP WARNING AND SAFETY INSTRUCTIONS

Mechanical Entrapment: When jewelry, swimsuit, hair decorations, finger, toe or knuckle is caught in an opening of an outlet or drain cover. This hazard is present when the drain cover is missing, broken, loose, cracked, or not properly secured.

NOTE: ALL SUCTION PLUMBING MUST BE INSTALLED IN ACCORDANCE WITH THE LATEST NATIONAL AND LOCAL CODES, STANDARDS AND GUIDELINES.

⚠ WARNING TO MINIMIZE THE RISK OF INJURY DUE TO SUCTION ENTRAPMENT HAZARD:

- A properly installed and secured ANSI/ASME A112.19.8 approved anti-entrapment suction cover must be used for each drain.
- Each suction cover must be installed at least three (3') feet apart, as measured from the nearest point to nearest point.
- Regularly inspect all covers for cracks, damage and advanced weathering.
- If a cover becomes loose, cracked, damaged, broken or is missing, replace with an appropriate certified cover.
- Replace drain covers as necessary. Drain covers deteriorate over time due to exposure to sunlight and weather.
- Avoid getting hair, limbs or body in close proximity to any suction cover, pool drain or outlet.
- Disable suction outlets or reconfigure into return inlets.

⚠ WARNING A clearly labeled emergency shut-off switch for the pump must be in an easily accessible, obvious place. Make sure users know where it is and how to use it in case of emergency.

The Virginia Graeme Baker (VGB) Pool and Spa Safety Act creates new requirements for owners and operators of commercial swimming pools and spas.

Commercial pools or spas constructed on or after December 19, 2008, shall utilize:

(A) A multiple main drain system without isolation capability with suction outlet covers that meet ASME/ANSI A112.19.8a Suction Fittings for Use in Swimming Pools, Wading Pools, Spas, and Hot Tubs and either:

- (i) A safety vacuum release system (SVRS) meeting ASME/ANSI A112.19.17 Manufactured Safety Vacuum Release systems (SVRS) for Residential and Commercial Swimming Pool, Spa, Hot Tub, and Wading Pool Suction Systems and/or ASTM F2387 Standard Specification for Manufactured Safety Vacuum Release Systems (SVRS) for Swimming pools, Spas and Hot Tubs or
- (ii) A properly designed and tested suction-limiting vent system or
- (iii) An automatic pump shut-off system.

Commercial pools and spas constructed prior to December 19, 2008, with a single submerged suction outlet shall use a suction outlet cover that meets ASME/ANSI A112.19.8a and either:

- (A) A SVRS meeting ASME/ANSI A112.19.17 and/or ASTM F2387, or
- (B) A properly designed and tested suction-limiting vent system, or
- (C) An automatic pump shut-off system, or
- (D) Disabled submerged outlets, or
- (E) Suction outlets shall be reconfigured into return inlets.

For Installation of Electrical Controls at Equipment Pad (ON/OFF Switches, Timers and Automation Load Center)

⚠ CAUTION Install all electrical controls at equipment pad, such as on/off switches, timers, and control systems, etc. to allow the operation (startup, shut-down, or servicing) of any pump or filter so the user does not place any portion of his/her body over or near the pump strainer lid, filter lid or valve closures. This installation should allow the user enough space to stand clear of the filter and pump during system start-up, shut down or servicing of the system filter.



⚠ DANGER



HAZARDOUS PRESSURE: STAND CLEAR OF PUMP AND FILTER DURING START UP

Circulation systems operate under high pressure. When any part of the circulating system (i.e. locking ring, pump, filter, valves, etc.) is serviced, air can enter the system and become pressurized.

Pressurized air can cause the pump housing cover, filter lid, and valves to violently separate which can result in severe personal injury or death. Filter tank lid and strainer cover must be properly secured to prevent violent separation. Stand clear of all circulation system equipment when turning on or starting up pump.

Before servicing equipment, make note of the filter pressure. Be sure that all controls are set to ensure the system cannot inadvertently start during service. Turn off all power to the pump. **IMPORTANT: Place filter manual air relief valve in the open position and wait for all pressure in the system to be relieved.**

Before starting the system, fully open the manual air relief valve and place all system valves in the "open" position to allow water to flow freely from the tank and back to the tank. Stand clear of all equipment and start the pump.

IMPORTANT: Do not close filter manual air relief valve until all pressure has been discharged from the valve and a steady stream of water appears. Observe filter pressure gauge and be sure it is not higher than the pre-service condition.

General Installation Information

- All work must be performed by a qualified service professional, and must conform to all national, state, and local codes.
- Install to provide drainage of compartment for electrical components.
- These instructions contain information for a variety of pump models and therefore some instructions may not apply to a specific model. All models are intended for use in swimming pool applications. The pump will function correctly only if it is properly sized to the specific application and properly installed.

⚠ WARNING Pumps improperly sized or installed or used in applications other than for which the pump was intended can result in severe personal injury or death. These risks may include but not be limited to electric shock, fire, flooding, suction entrapment or severe injury or property damage caused by a structural failure of the pump or other system component.

⚠ WARNING The pump can produce high levels of suction within the suction side of the plumbing system. These high levels of suction can pose a risk if a person comes within the close proximity of the suction openings. A person can be seriously injured by this high level of vacuum or may become trapped and drown. It is absolutely critical that the suction plumbing be installed in accordance with the latest national and local codes for swimming pools.

Warnings and safety instructions for Pentair Aquatic Systems pumps and other related products are available at:
<http://www.pentairpool.com/pool-owner/safety-warnings/> or call (800) 831-7133 for additional free copies of these instructions.

Please refer to <http://www.pentairpool.com/pool-owner/safetywarnings/> for warning and safety instructions related to the this product.

SAVE THESE INSTRUCTIONS

PUMP OVERVIEW

The IntelliFloXF® and IntelliProXF® Variable Speed Pump can be programmed to run at specific speeds and time intervals for maximum operating efficiency and energy conservation for in-ground pools.

- The pump can operate from 450 RPM to 3450 RPM with four preset speeds of 750, 1500, 2350 and 3110 RPM
- The pump can be adjusted from the control panel to run at any speed between 450 RPM to 3450 RPM for different applications
- Up to 8 programmable speeds
- Pump control panel alarm LED and error messages warn the user against under and over voltage, high temperature, over current and freeze protection
- Communicates with EasyTouch®, IntelliTouch® or SunTouch® Control Systems or IntelliComm® Communication Center via a two-wire RS-485 cable connection
- Self-priming for easy start-up
- Totally enclosed fan-cooled (TEFC) motor design
- UL/CUL/NSF

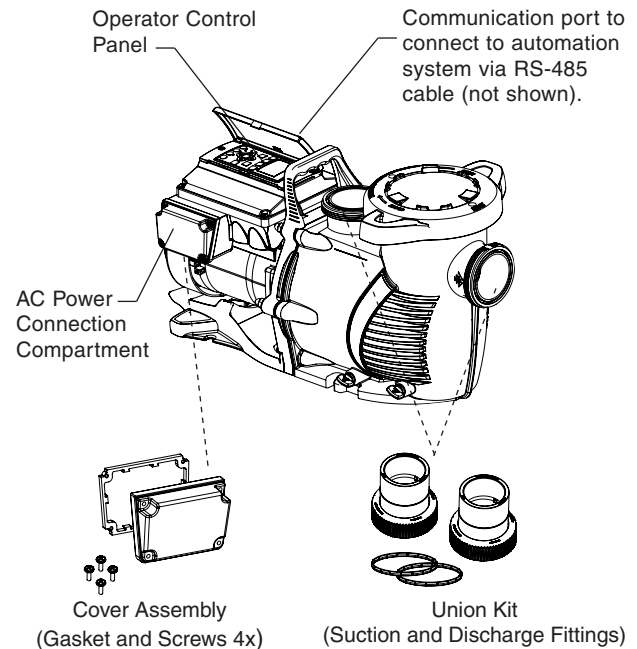

Union Adapter Installation

Installing the locking union onto the pump:

1. Glue the PVC union adapter fitting to the PVC pipe. The adapter accepts 2.5" PVC pipe internally or a 3" PVC coupling externally.

Note: Be sure that the groove for the retainer ring is on the end opposite your glue joint.

2. Slip the nut onto the fitting.
3. Place the flat side of the retainer ring against the adapter on the grooved end.
4. Gently flex the locking clip union nut retainer ring into its place in the groove on the adapter.
5. Start snapping it in at one end of the ring and work your way around.

The tab features should point out away from the nut and the glue joint towards the sealing surface.

6. Slide the nut over the ring and attach it to the pump.

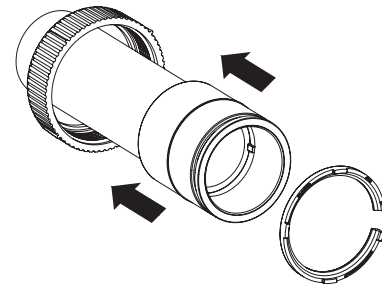

Slip the nut onto the fitting.

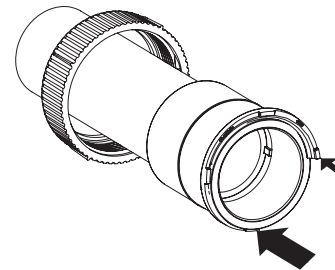

Snap retainer ring around the adapter.

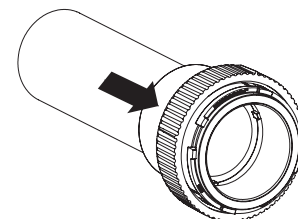

Slide the nut over the adapter

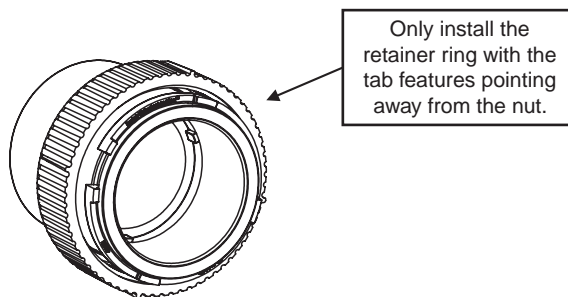

Union Nut and Adapter

INSTALLATION

Only a qualified plumbing professional should install the IntelliFloXF® and IntelliProXF® Variable Speed Pumps. Refer to “*Pump Warning And Safety Instructions*” on pages ii - iv for additional installation and safety information.

Location

Be sure the pump location meets the following requirements:

Note: Do not install this pump within an outer enclosure or beneath the skirt of a hot tub or spa unless marked accordingly.

1. Install the pump as close to the pool or spa as possible. To reduce friction loss and improve efficiency, use short, direct suction and return piping.
2. Install a minimum of 5 feet (1.52 meters) from the inside wall of the pool and spa. Canadian installations require a minimum of 9.8 feet (3 meters) from the inside wall of the pool.
3. Install the pump a minimum of 3 feet (.9 meters) from the heater outlet.
4. Do not install the pump more than 10 feet (3 meters) above the water level.
5. Install the pump in a well ventilated location protected from excess moisture (i.e. rain gutter downspouts, sprinklers, etc.).
6. Install the pump with a rear clearance of at least 3 inches (7.6 cm) so that the motor can be removed easily for maintenance and repair.

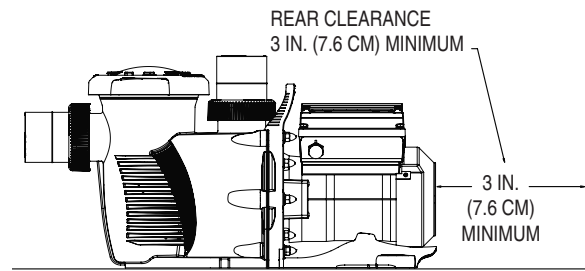

Pump Rear Clearance

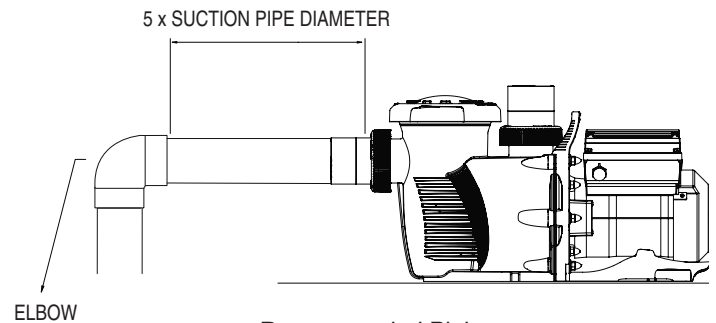

Recommended Piping

Piping

1. For improved pool plumbing, it is recommended to use a larger pipe size. When installing the inlet and outlet fittings (male adaptors), use thread sealant.
2. Piping on the suction side of the pump should be the same or larger than the return line diameter.
3. Plumbing on the suction side of the pump should be as short as possible.
4. It is recommended that a valve, elbow or tee installed in the suction line should be no closer to the front of the pump than five (5) times the suction line pipe diameter.

Example:

A 2.5 inch pipe requires a 12.5 inch (31.8 cm) straight run in front of the suction inlet of the pump). This will help the pump prime faster and last longer.

Fittings and Valves

1. Do not install 90° elbows directly into pump inlet.
2. Flooded suction systems should have gate valves installed on suction and discharge pipes for maintenance, however, the suction gate valve should be no closer than five times the suction pipe diameter as described in this section.
3. Use a check valve in the discharge line when using this pump for any application where there is significant height to the plumbing after the pump.
4. Be sure to install check valves when plumbing in parallel with another pump. This helps prevent reverse rotation of the impeller and motor.

Electrical

- Install all equipment in accordance with the National Electrical Code and all applicable local codes and ordinances.
- A means for disconnection must be incorporated in the fixed wiring in accordance with the wiring rules.

Electrical Wiring Installation

⚠ WARNING



RISK OF ELECTRICAL SHOCK OR ELECTROCUTION. This IntelliFloXF® or IntelliProXF® Variable Speed Pump must be installed by a licensed or certified electrician or a qualified service professional in accordance with the National Electrical Code and all applicable local codes and ordinances. Improper installation will create an electrical hazard which could result in death or serious injury to users, installers, or others due to electrical shock, and may also cause damage to property.

Always disconnect power to the pump at the circuit breaker before servicing the pump. Failure to do so could result in death or serious injury to service people, users or others due to electric shock.

Read all servicing instructions before working on the pump.

To connect the pump to an AC power source:

1. Be sure all electrical breakers and switches are turned off before wiring motor.
2. Be sure that the supply line voltage matches the motor voltage listed on the motor plate (example 230 VAC or 115 VAC). If they do not match, permanent motor damage may occur.
3. For wiring sizes and general guidelines for proper electrical installation, please follow the specifications defined in the National Electric Code and any local codes as required.
4. Use strain relief and be sure all electrical connections are clean and tight.
5. Cut the wires to the appropriate length so they do not overlap or touch when connected.
6. Permanently ground the motor using the green ground wire. Use the correct wire size and type specified by National Electrical Code. Make sure the ground wire is connected to an electrical service ground.
7. Bond the motor to the pool structure in accordance with the National Electrical Code. Use a solid copper bonding conductor not smaller than 8 AWG. Run a wire from the external bonding screw or lug to the pool bonding structure.
8. Connect the wire from the accessible bonding lug on the motor to all metal parts of the swimming pool, spa, or hot tub structure and to all electrical equipment, metal conduit, and metal piping within 5 feet (1.52 meters) of the inside walls of the swimming pool, spa, or hot tub. For Canada, a 6 AWG or larger solid copper bonding conductor is required.
9. The pump should be permanently connected to either a circuit breaker, 2-pole timer or 2-pole relay. If AC power is supplied by a GFCI circuit breaker, use a dedicated circuit breaker that has no other electrical loads.
10. **IMPORTANT:** When connecting the pump to an automation system (IntelliTouch®, EasyTouch®, SunTouch® Control Systems and IntelliComm® Communication Centers), continuous power must be supplied to the pump by connecting it directly to the circuit breaker. When using an automation system, be sure that no other lights or appliances are on the same circuit.

Note: When the pump is started and stopped by removing power with a relay or timer, a two-pole device should be used to apply and remove power to both POWER LINE TERMINALS.

Pentair offers 2-Pole 20 Amp GFCI breakers (P/N PA220GF) which offer 6 milliamp personnel protection while meeting 2008 to current NEC Standards for Pool Pumps.

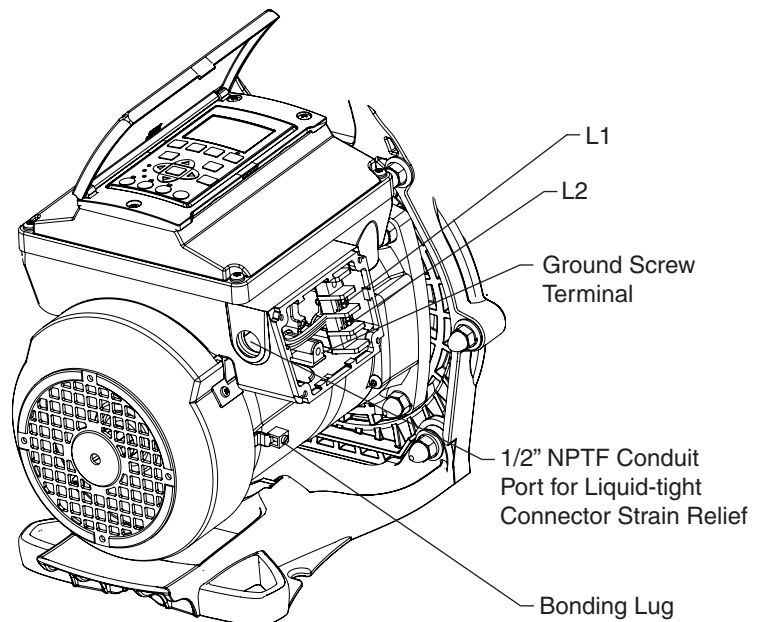

Field Wiring Compartment

OPERATING THE PUMP

NOTE: Speed 1 is the default filtration speed. When setting up the IntelliFloXF® Variable Speed Pump, the user must set the pump's internal clock and establish an operation schedule by following the steps in this manual. Please refer to user's guide sections: 'Set Time' (page 8) and 'Set Speeds 1-8 in Schedule Mode' (page 12) to schedule a time to run the pump.

CAUTION

This pump is shipped with Priming mode ENABLED. Unless the Priming settings are changed in the menu, **be aware that the pump will speed up to the maximum speed when the pump is powered on for the first time, and the start/stop button is pressed.** To change the maximum speed of the pump, refer to page 9.

Before turning the pump ON, be sure the following conditions are met:

1. Open filter air relief valve.
2. Open valves.
3. Pool return is completely open and clear of any blockages.
4. Water in the pump basket.
5. Stand clear of the filter or other pressurized vessels.

Priming the Pump

Prime the pump before starting the pump for the first time. To avoid permanent damage to the pump, remove the lid and fill the basket with water. The pump basket must be filled with water before initial start up or after servicing.

Follow the steps below to prime the pump for start up:

1. Press **Start/Stop** to stop the pump. Disconnect the pump main power supply and communication cable.
2. Close all gate valves in suction and discharge pipes. Relieve all pressure from the system.
3. Remove the pump lid and locking ring.
4. Fill the pump strainer pot with water.
5. Reassemble the pump lid and locking ring onto the strainer basket. The pump is now ready to prime.
6. Open the filter air relief valve and stand clear of the filter.
7. Connect power to the pump. Be sure green power light is on.
8. Press **Start/Stop** to start the pump. The pump will enter into priming mode (if enabled) and speed up to the maximum speed set in the pump menu settings.
9. When water comes out of the filter air relief valve, close the valve. The system should now be free of air and recirculating water to and from the pool.
10. Do not allow your pump to run longer than 30 minutes time without developing full flow. If the pump does not prime, check your priming settings on the control panel or see the "Troubleshooting" section on pages 24-25.

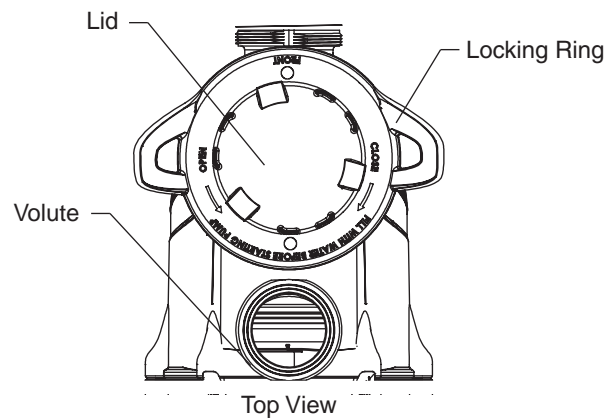

Priming Features

The default priming setting is ENABLED. The pump also allows you to set the following from the operator control panel:

- Maximum priming time
- Maximum and Minimum speed
- Priming sensitivity (1-100%)
- Priming delay

Set up instructions on page 14.

CAUTION

DO NOT run the pump dry. If the pump is run dry, the mechanical seal will be damaged and the pump will start leaking. If this occurs, the damaged seal must be replaced. ALWAYS maintain proper water level in your pool (half way up skimmer opening). If the water level falls below the skimmer opening, the pump will draw air through the skimmer, losing the prime and causing the pump to run dry, resulting in a damaged seal. Continued operation in this manner could cause a loss of pressure, resulting in damage to the pump case, impeller and seal and may cause property damage and personal injury.

CAUTION

Do not add chemicals to the system directly in front of pump suction. Adding undiluted chemicals may damage the pump and will void the warranty.

CAUTION

This is a variable speed pump. Typically the lower speeds are used for filtration and heating. The higher speeds can be used for spa jets, water features, and priming.

Using the Operator Control Panel

Use the operator control panel to start and stop the IntelliFloXF® Variable Speed Pump, program, set, and change speeds (RPM), and access pump features and settings.

Controls and LEDs on Key Pad

- ① **Speed 1:** Press to select Speed 1 (750 RPM). LED on indicates Speed 1 is active.
- ② **Speed 2:** Press to select Speed 2 (1500 RPM). LED on indicates Speed 2 is active.
- ③ **Speed 3:** Press to select Speed 3 (2350 RPM). LED on indicates Speed 3 is active.
- ④ **Speed 4:** Press to select Speed 4 (3110 RPM). LED on indicates Speed 4 is active.
- ⑤ **Select:** Press to select the currently displayed option on the screen.
- ⑥ **Escape:** Goes one step back in menu; exits without saving current setting.
- ⑦ **Menu:** Accesses the menu items when and if the pump is stopped.
- ⑧ **Enter:** Saves current menu item setting. Press this button to acknowledge alarms and warning alerts.
- ⑨ **Arrow buttons:**
 - **Up arrow:** Move one level up in the menu or increase a digit when editing a setting.
 - **Down arrow:** Move one level down in the menu or decrease a digit when editing a setting.
 - **Left arrow:** Move cursor left one digit when editing a setting.
 - **Right arrow:** Move cursor right one digit when editing a setting.
- ⑩ **Quick Clean:** Pump ramps up to higher RPM for vacuuming, cleaning, adding chemicals, and after a storm for extra skimmer power. LED light is on when active.
- ⑪ **Time Out:** Pump is not running on preset schedule. This can be used to allow newly glued pipe joints time to dry before circulation of water starts. LED is on when active.
- ⑫ **Start/Stop button:** To start or stop the pump. When LED is on, the pump is running or in a mode to start automatically.
- ⑬ **Reset button:** Reset alarm or alert.
- ⑭ **LEDs:**
 - ✓ **On:** Green light when pump is powered on.
 - ! **Warning:** On if warning condition is present.
 - ! **Alarm:** Red LED on if alarm condition occurs. See "Alerts and Warnings" on page 23.
- ⑮ **Control Panel LCD Screen:**
 - **Line 1:** Key icon indicates password protect mode is active. If password protect is not enabled, no key icon is displayed. Also shows current time of day.
 - **Line 2:** Displays current pump speed (RPM).
 - **Line 3:** Countdown time and watts
 - **Line 4:** Current pump status and current feature.

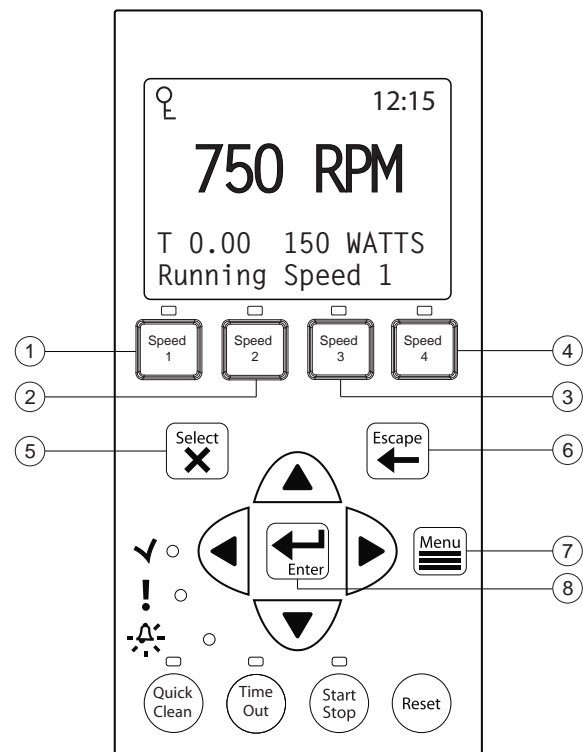

Control Panel #1-8

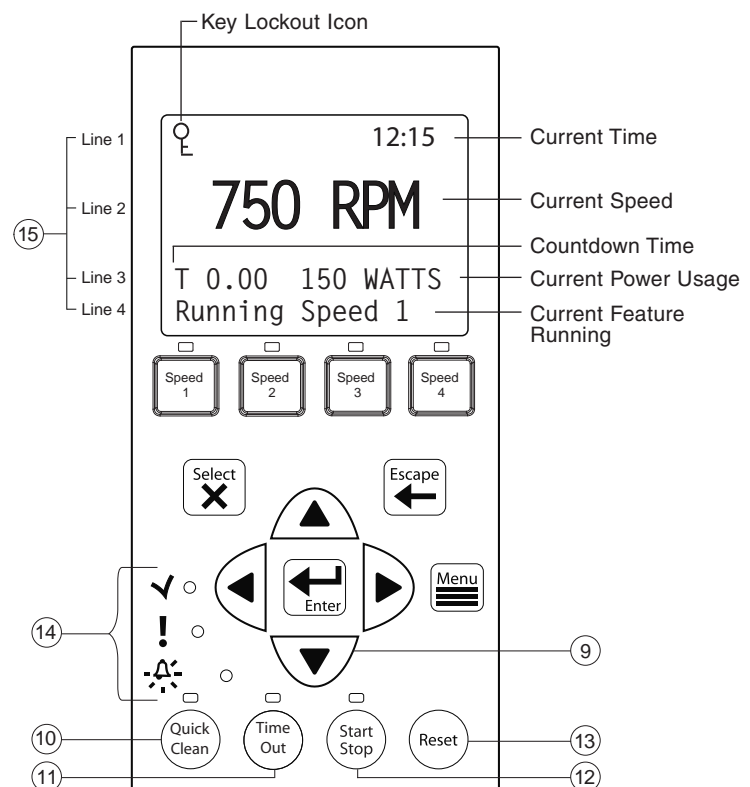

Control Panel #9-15

Stopping and Starting the Pump

Starting the Pump

1. Be sure the IntelliFloXF® Variable Speed Pump is powered on and the green power LED is on.
2. Select one of the speed buttons, then press the **Start/Stop** button (LED on) to start the pump. The pump will go into priming mode if priming feature is enabled.

Stopping the Pump

1. Press **Start/Stop** to stop the pump.

When servicing equipment (filters, heaters, chlorinators etc.), disconnect the communication cable, and switch OFF circuit breaker to remove power from the pump.

Note: The pump can automatically restart if the communication cable is connected.

To Adjust and Save a Pump Speed

1. While the pump is running, press the **Up** or **Down** arrow to adjust to desired speed setting.
2. Press and hold down a **Speed** button (1-4) for three (3) seconds to save speed to the button or press **Enter** to save the speed.

Operating the Pump at Preset Speeds

The pump is programmed with four default speeds of 750, 1500, 2350 and 3110 RPM. Speed buttons 1-4 are for each of the preset speeds.

1. Be sure the pump is powered on and the green power LED is on.
2. Press the **Speed** button (1- 4) corresponding to the desired preset speed and release quickly. The LED above the button will turn on.
3. Press **Start/Stop**. The pump will quickly change to the selected preset speed.

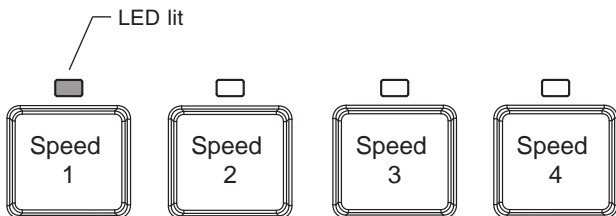

Pump Operating Modes

The pumps can be programmed in three different modes: **Manual, Schedule, and Egg Timer.**

Speeds 1-4 can be programmed in all three modes. Speeds 5-8 can only be programmed in Schedule mode since there are no buttons on the control panel for Speeds 5-8. The default setting for Speeds 5-8 is “Disabled”.

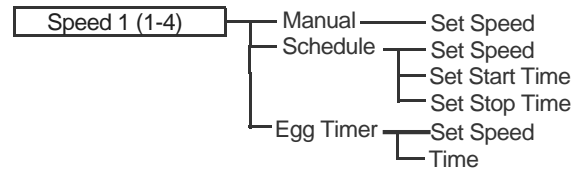

Speeds 1-4 Menu Guide

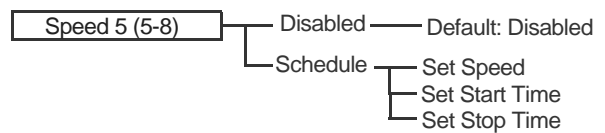

Speeds 5-8 Menu Guide

1. **Manual:** Assigns a speed to one of the four Speed buttons on the control panel. This mode can only be used for speeds 1-4.

To operate in Manual mode, press one of the four speed buttons and then press Start/Stop. The pump will run the assigned speed for that speed button.

2. **Egg Timer:** Speeds 1-4 can be programmed to run for a duration of time once a speed button is pressed. To operate in Egg Timer mode, press a speed button and then press Start/Stop. The pump will run that speed for the set amount of time and then turn off.
3. **Schedule:** Program speeds 1-8 start and stop at a specific time during a 24 hour period. Speeds programmed in Schedule mode will override any manually selected speed (speeds set by manually pressing any of the speed buttons on the control panel).

Control Panel Language

The default language is English.

1. Check that the green power LED is on.
2. Press **Menu** and press Select to select “Settings”.
3. Use the **Up** or **Down** arrows and scroll to “Language”.
4. Press **Select**. Press **Select** again to highlight current language in use.
5. Press **Enter** to select the control panel language. To cancel any changes, press **Escape** to exit without saving.
6. Press **Escape** to exit.

Operator Control Panel: Pump Menu Guide

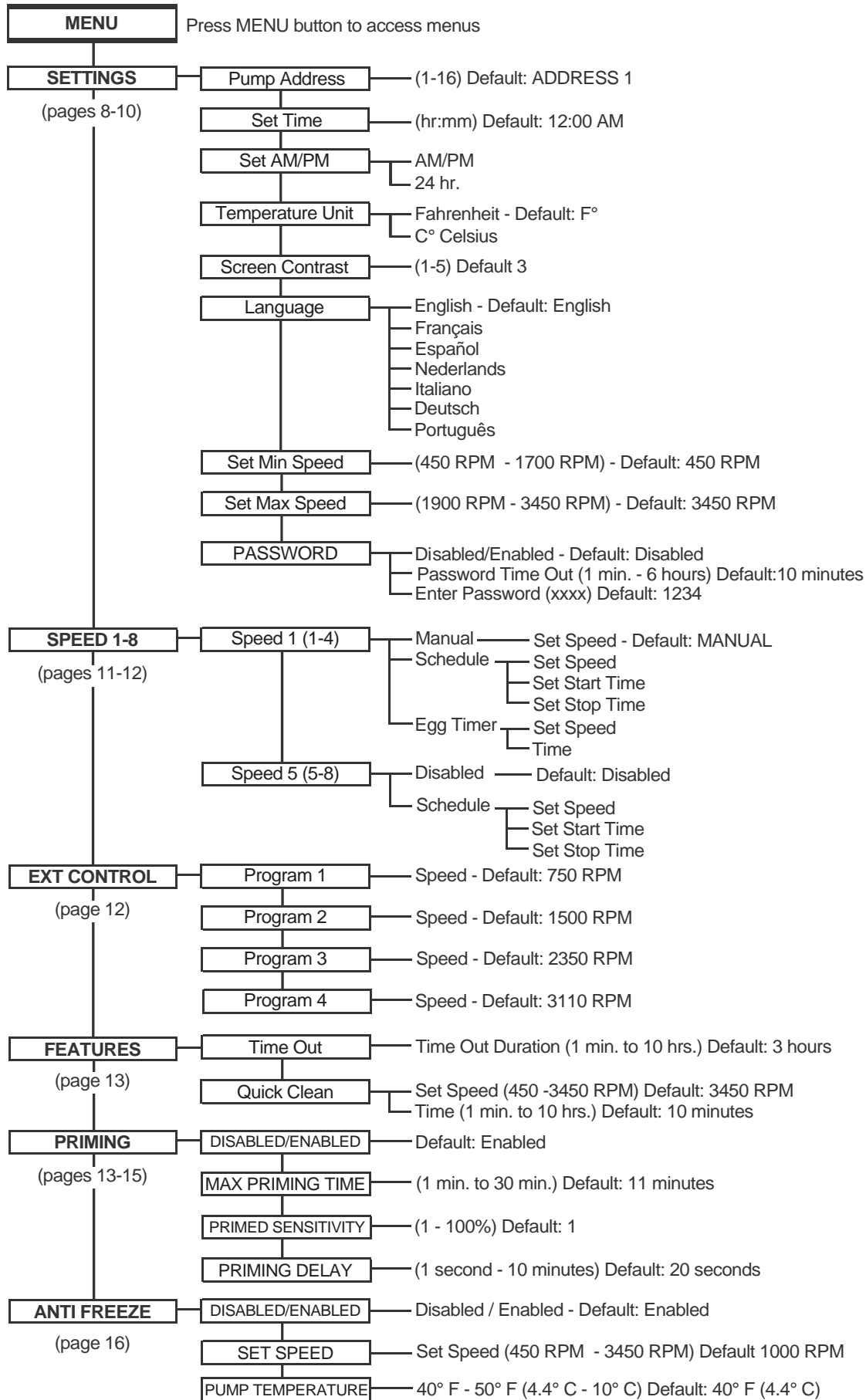



Pump Address

The default pump address is #1 and only needs to be changed when there is more than one IntelliFloXF® or IntelliProXF® (or IntelliFlo® and IntelliPro®) Variable Speed Pump on an automation system. Change the address to allow the automation system to send a command to the correct pump.

Use this setting if your pump is connected via the RS-485 COM port to an IntelliTouch®, EasyTouch®, SunTouch® Control System or IntelliComm® Communication Center. For EasyTouch, SunTouch or IntelliComm systems, the pump only communicates with address #1. The pump address can be set from 1-16. The IntelliTouch system can communicate only to four (1-4) pumps.

Note: IntelliFloXF and/or IntelliProXF pumps cannot be connected in series with other pumps.

1. Be sure the green power LED is on and the pump is stopped.
2. Press **Menu**.
3. Press **Select** for “Settings”. Press **Select** again to select “Pump Address”.
4. To change the pump address, press **Select**.
5. Press **Up** or **Down** arrows to change the address number from 1-16.
6. Press **Enter** to save. To cancel any changes, press **Escape** to exit without saving.
7. Press **Escape** to exit.

Set Time

The time controls all scheduled times, functions, and programmed cycles and stores the correct time for up to 96 hours after power is turned off. Reset if the power is off longer than 96 hours.

1. Check that the green power LED is on.
2. Press **Menu**.
3. Press **Select** to select “Settings”.
4. Use the **Up** or **Down** arrows to scroll to “Set Time” and press **Select**.
5. Use **Up** or **Down** arrows to set the time.
Note: To change AM/PM, increase or decrease numbers until the desired time is displayed.
6. Press **Enter** to save. To cancel any changes, press **Escape** to exit without saving.
7. Press **Escape** to exit.

Set AM/PM or 24 Clock

To change the time from a 12 hour clock (AM/PM) to a 24 hour clock:

1. Press **Menu**.
2. Press **Select** to select “Settings”.
3. Use the **Up** or **Down** arrows to scroll to “AM/PM.”
4. Press **Select** to change the setting.
5. Press **Up** or **Down** arrows to choose between 24 hr. and AM/PM.
6. Press **Enter** to save. To cancel any changes, press **Escape** to exit without saving.
7. Press **Escape** to exit.

Set Temperature Unit

The default setting is Fahrenheit (°F). The pump can be set to either Celsius (°C) or Fahrenheit (°F). The Anti Freeze protection feature (see page 16) can be set to either Fahrenheit or Celsius.

1. Check that the green power LED is on.
2. Press **Menu**.
3. Press **Select** to select “Settings”.
4. Use the **Up** or **Down** arrows to scroll to “Temperature Units” menu item. Press **Select**.
5. Use **Up** or **Down** arrows to choose Celsius (°C) or Fahrenheit (°F).
6. Press **Enter** to save. To cancel any changes, press **Escape** to exit without saving.
7. Press **Escape** to exit.

Set Screen Contrast

The default setting for the LCD screen is 3. Screen contrast levels can be adjusted from 1 to 5 units for low or high lighting conditions.

1. Check that the green power LED is on.
2. Press **Menu**.
3. Press **Select** to select “Settings”.
4. Use the **Up** or **Down** arrow to scroll to “Contrast Level”.
5. Press **Select**. Screen will show current contrast setting number.
6. Use **Up** or **Down** to change number.
7. Press **Enter** to save. To cancel any changes, press **Escape** to exit without saving.
8. Press the **Escape** button to exit.



Language

To access the language menu:

1. Check that the green power LED is on.
2. Press the **Menu** button. “Settings” is displayed.
3. Press the **Select** button. “Pump Address” is displayed.
4. Use the **Up** or **Down** arrow button to scroll to “Language”.
5. Press the **Select** button to access the language menu.
6. Press **Select** to highlight current Language in use.
7. Press the **Enter** button to select the desired language for the control panel. To cancel any changes, press the **Escape** button to exit edit mode without saving.
8. Press the **Escape** button to exit.

Set Maximum Speed (RPM)

The maximum speed can be set from 1900 RPM to 3450 RPM (default is 3450). Use this setting to set the maximum running speed of the pump.

When the IntelliFloXF® Variable Speed Pump is set to Priming “Enabled”, the pump will speed up to and run at this speed to prime. A service professional must set the Maximum Speed of the pump to not exceed the maximum flow rate of the system on which it will operate.

CAUTION The Maximum Flow rate setting should be set so the system never operates at or above 25” of Hg vacuum.

1. Check that the green power LED is on.
2. Press **Menu**.
3. Press **Select** to select “Settings”.
4. Use the **Up** or **Down** arrows to scroll to “Set Max Speed”.
5. Press **Select** to change. The cursor will appear in the first number column (ones).
6. Press **Up** or **Down** arrows to change the maximum speed setting from 1900 to 3450 RPM.
7. Press **Enter**. Press **Escape** to exit. To cancel, press the **Escape** to exit without saving.

Set Minimum Speed (RPM)

The minimum pump speed can be set from 450 RPM to 1700 RPM. The default setting is 450 RPM.

1. Check that the green power LED is on.
2. Press **Menu**.
3. Press **Select** to select “Settings”.
4. Use the **Up** or **Down** arrows to scroll to “Set Min Speed”.

5. Press **Select** to change the setting. The cursor will appear in the first number column.
6. Press the **Up** or **Down** arrows to change the minimum speed setting from 450 to 1700 RPM.
7. Press **Enter** to save. To cancel, press **Escape** to exit edit mode without saving.
8. Press **Escape** to exit.

Password Protection

The default setting for password protection is disabled. When this feature is enabled, the pump display will prompt for the password before allowing access to the control panel and buttons.

The entered password is any combination of four (4) digits.

- Password protection can always be turned off by pressing **Start/Stop**.
- Password protection cannot be turned back on with **Start/Stop** while running in manual mode.
- Pressing **Start/Stop** when the pump is off will return it back to the Running Cycles Mode and run at the next scheduled run time. If the present time is within the scheduled run time, the pump will run the scheduled speed.
- All functions including programming are disabled in Password Protection Mode.
- Screen will read “Enter Password” if any button other than the **Start/Stop** button is pressed.
- Key icon displayed in the upper left side of the screen when Password Protection is on.

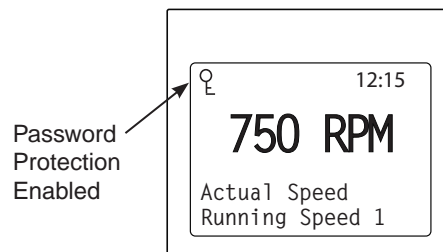



Setting Password

1. Check that the green power LED is on.
2. Press **Menu**. Press **Select** to select “Settings”.
3. Use the **Up** or **Down** arrow to scroll to “Password”.
4. Press **Select**. The default setting is “Disabled”.
5. To change this setting, press **Select**. Press **Up** or **Down** arrow to change the setting to “Enabled” and press **Enter** to save.
6. Press the **Down** arrow. “Password Timeout” is displayed.
7. The factory default time is 10 minutes. This means the IntelliFloXF® Variable Speed Pump will go into Password Protection mode 10 minutes after the last control panel key is pressed.
8. Press **Select** to change time setting from 1 minute to 6 hours and press **Enter** to save.
9. Press **Down** arrow and then press **Select** on “Enter Password” to change the password.
10. Press the **Left** or **Right** arrows to move cursor and press **Up** or **Down** arrow to change the password.
11. Press **Enter** to save. To cancel any changes, press **Escape** to exit without saving.

Entering Password

1. Press any button (besides the speed button) to prompt the screen for a password.
2. To enter password, use the **Left** and **Right** arrows to move the cursor and the **Up** and **Down** arrow button to scroll through the digit then press **Enter** to confirm.



Pump Operating Modes

The IntelliFloXF® and IntelliProXF® Variable Speed Pumps can be programmed in three different modes: *Manual, Schedule, and Egg Timer.*

Speeds 1-4 can be programmed in all three modes. Speeds 5-8 can only be programmed in Schedule mode since there are no buttons on the control panel for Speeds 5-8. The default setting for Speeds 5-8 is “Disabled”.

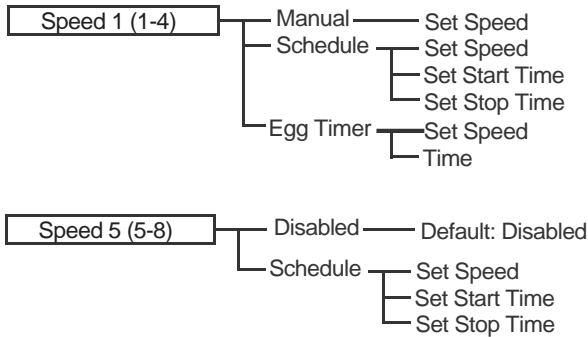

Speed Menu Tree Options

Manual

Assigns a speed to one of the four Speed buttons on the control panel. This mode can only be used for speeds 1-4.

To operate in Manual mode, press one of the four speed buttons and then press the Start/Stop button. The pump will run the assigned speed for that speed button.

Egg Timer

Speeds 1-4 can be programmed to run for a duration of time once a speed button is pressed.

To operate in Egg Timer mode, press a speed button and then press Start/Stop. The pump will run that speed for the set amount of time and then turn off.

Schedule

Program speeds 1-8 start and stop at a specific time during a 24 hour period. Speeds programmed in Schedule mode will override any manually selected speed (speeds set by manually pressing any of the speed buttons on the control panel).

Set Speeds in Manual or Egg Timer Mode (Speeds 1-4 Only)

1. Press **Menu**.
2. Use **Up** or **Down** arrows to scroll to “Speed 1-8”, then press **Select**.
3. Use **Up** or **Down** arrows to find the speed (1-4) you wish to program.
4. Press **Select**. Speeds 1-4 default setting is **Manual**. To set a speed in Manual mode, press the **Down** arrow (“Set Speed” will display) and press **Select** to change. Use the **Up** or **Down** arrow to adjust speed.
5. Press **Enter** to save the new speed setting.
Continue below to Step 6 to set a speed in Egg Timer mode.
6. Press **Select** and scroll to “Egg Timer”. Press **Enter**.
7. Press the **Down** arrow to display “Time”.
8. Press **Select** and use arrow keys to adjust time.
9. Press **Enter** to save the new time setting.
10. Press **Escape** to exit.

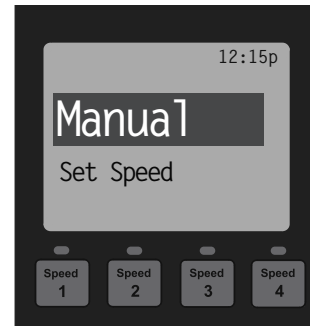

Manual Mode Menu Screen



Egg Timer Menu Screen



Set Speeds 1-8 in Schedule Mode

In Schedule mode, Speeds 1-8 can be programmed to run a certain speed at a certain time of day. To run a scheduled speed, press Start/Stop. The screen will display “Running Schedules” when it is ready to run a scheduled speed. If Start/Stop is pressed while a scheduled speed is running, “Running Speed _” will be displayed (see far left image).

1. Press **Menu**.
2. Use **Up** or **Down** arrows to scroll to “Speed 1-8”, then press **Select**.
3. Use **Up** or **Down** arrows and press **Select** for the speed you wish to set and schedule.
4. Press **Select** (display will be highlighted) and scroll to “Schedule”.
5. Press **Enter**.
6. Press **Down** arrow (“Set Speed” will display) and press **Select** to change. Use the **Up** or **Down** arrow to adjust speed.
7. Press **Enter** to save the new speed.
8. Press the **Down** arrow again, “Set Start Time” will display. Press **Select** - the cursor will highlight the minute column.
9. Use the **Up** or **Down** arrow to change the time and the **Left** or **Right** arrow to move cursor from minutes to hours.
10. Press **Enter** to save the new start time setting.
11. Press **Down** arrow - “Set Stop Time” will display. Press **Select**. Repeat Steps 8-9 to set stop time.
12. Press **Enter** to save the new stop time setting.
13. Press **Start/Stop**.

The IntelliFloXF® Variable Speed Pump will prime and begin to run the programmed schedule at the specified start time.

When running in Schedule or Egg Timer mode, the countdown time (T 00:01) showing the hours and minutes remaining is displayed.

Programming Schedule for Constant Run

A speed cannot be programmed with the same start and stop times. To run a speed without stopping, set the Start time one minute after the stop time.

Example: A single speed will run non stop if programmed with a Start Time of 8:00 AM and a Stop time of 7:59 AM.

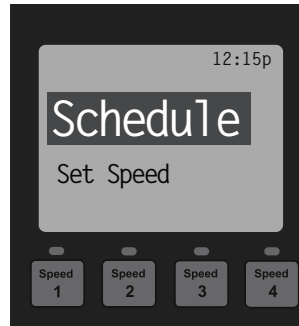

Setting Schedule Mode



Display During Schedule Mode

Note: The pump will not run the scheduled speeds until the **Start/Stop** button is pressed (LED on) to place the pump in Schedule mode.

Note: When two speeds are scheduled during the same run time the pump will run the higher RPM Speed regardless of Speed # in use.

Note: The most recent command, Manual or Schedule, takes priority regardless of speed number RPM.



External Control

This function is for programming speeds that will run when the IntelliComm® Communication Center sends it a command. For example, Terminal 3 and 4 in IntelliComm system will correspond to External Control Program #1. (5 and 6 to Ext Ctrl #2). Use the External Control feature to program the IntelliComm system power center.

To access the External Control menu:

1. Check that the green power LED is on.
2. Press the **Menu** button.
3. Use **Up** or **Down** arrow to scroll to “Ext. Ctrl.”.
5. Press **Select**. “Program 1” is displayed.
6. Press **Select** to change the speed. The “RPM” number will highlight.
7. Press **Up** or **Down** arrow to change the RPM setting.
8. Press **Enter** to save the setting.
- Note:** To cancel any changes, press the **Escape** button to exit without saving.
9. Press **Escape** to return to set Program 2.
10. Use **Up** or **Down** arrow to scroll to “Program 2”.
11. Repeat Steps 6 through 10 to set Program 2, 3, and 4.

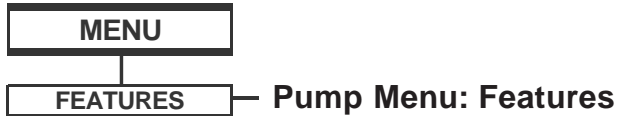

Quick Clean

NOTE: Quick Clean is the only high-speed override feature of the IntelliFloXF® and IntelliProXF® Variable Speed Pumps.

This feature can be used to ramp the pump up to a higher RPM for vacuuming, cleaning, adding chemicals, after a storm for extra skimming capability.

Press the **Quick Clean** button (LED on) and then **Start/Stop** to start. When the Quick Clean cycle is over, the pump will resume regular schedules and be in “Running Schedule” mode.

To access the Quick Clean menu:

1. Check that the green power LED is on.
2. Press **Menu**.
3. Use **Up** or **Down** arrows to scroll to “Features”, then press **Select**.
4. Press the **Down** arrow and press **Select** for “Quick Clean”.
7. Press **Select** to choose “Set Speed”.
8. Press **Select** to highlight the “RPM” first (ones) column and change the speed.
9. Use **Up** or **Down** arrows to change the speed.
10. Press **Enter** to save the speed.
11. Press the **Down** arrow again, and press **Select** for “Time Duration”.
12. Press **Select** to change the time. The cursor will highlight the minutes column.
13. Use **Up** or **Down** arrows to change the time from 1 minute to 10 hours.
14. Press **Enter** to save the time.
15. Press **Escape** to exit the menu.

Time Out

This feature can be used to allow newly glued pipe joints time to dry before circulation of the pool water resumes. *The Time Out feature keeps the pump from running its programmed speeds.*

Once Time Out is finished, the pump will be in “Running Schedule” mode, the Start/Stop LED will be lit and ready to turn on at the next scheduled run time.

To access the Time Out menu:

1. Check that the green power LED is on.
2. Press **Menu**.
3. Use **Up** or **Down** arrows to scroll to “Features”, then press **Select**.
5. Press **Select** to choose “Timeout”.

6. Then press **Select** again to choose “Timeout Duration”.
7. Press **Select** to change the time. The cursor will highlight the minutes column.
8. Press the **Left** arrow to move cursor to the hours column. Time out can be set from 1 minute to 10 hours.
9. Press **Enter** to save the setting.

Note: To cancel any changes, press **Escape** to exit without saving.
10. Press **Escape** to exit the menu.



The default setting for Priming is ENABLED. This setting allows the pump to automatically detect if it is primed for startup.

The priming feature ramps the pump to 1800 RPM and pauses for three (3) seconds. If there is sufficient water flow in the pump basket, the pump will go out of priming mode and run its commanded speed.

If the water flow is not sufficient, the pump will ramp to the “Max Speed” setting and remain for the priming delay time (default 20 seconds). If there is sufficient water flow in the pump basket at this time, it will go out of priming mode and ramp to the commanded speed.

If there is still insufficient flow in the pump basket, the pump will try to prime at the “Maximum Speed” for the amount of time set up in the “Maximum Priming Time” menu.

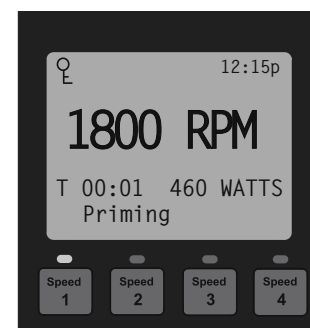

Display during priming

Continue onto the next page for Priming Features



Priming Features

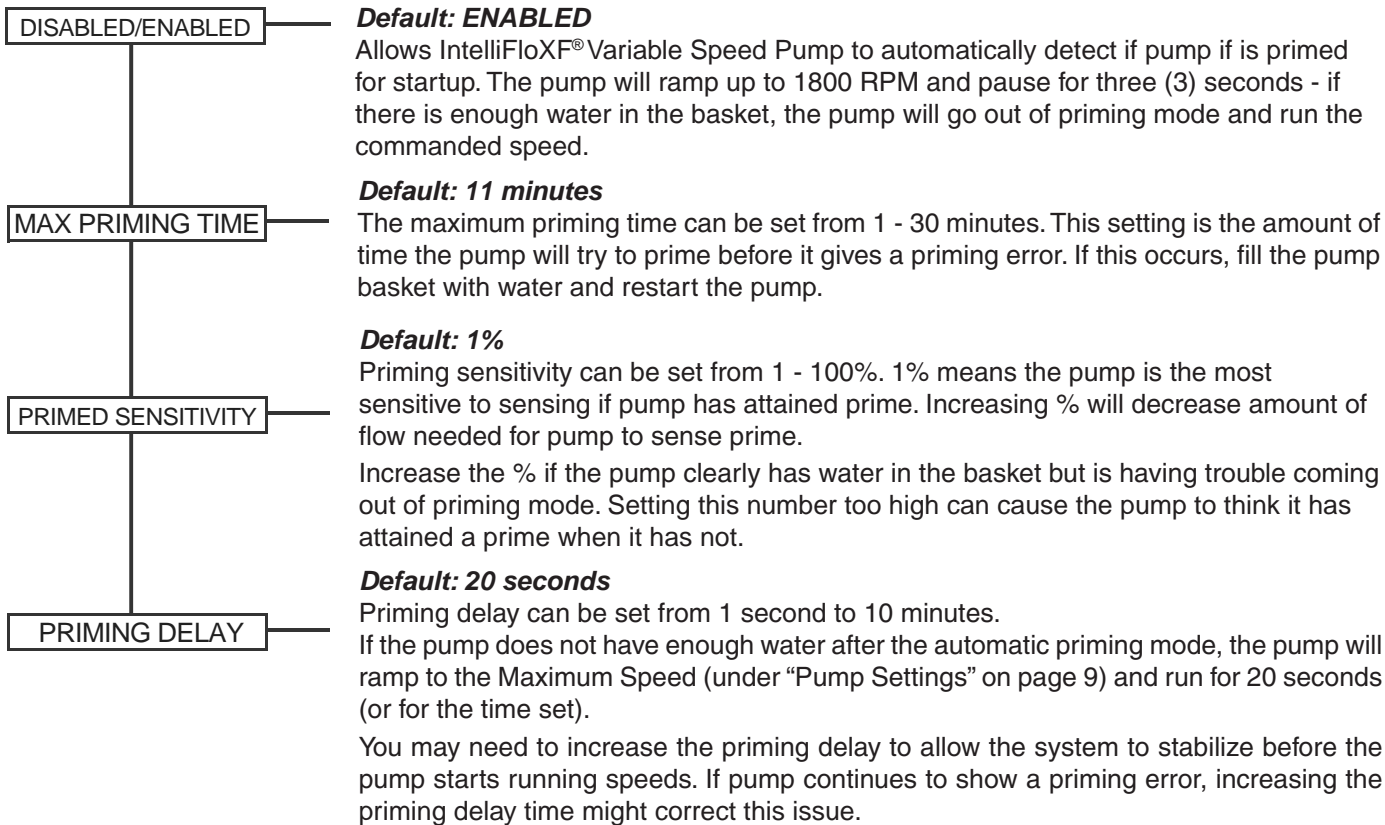

Setting Priming Features

1. Press **Menu**.
2. Use **Down** arrow to scroll to “Priming” and press **Select**.
3. The factory default is set to priming “Enabled”. To disable, press **Select**.
4. Press **Enter** if you have changed the setting - this will save the selection.
5. Press the **Down** arrow - the screen will read “Max Priming Time”.
6. To change from factory default, press **Select**. The cursor will highlight.
7. Use the **Up** or **Down** arrows to change the time from 1 minute to 30 minutes.
8. Press **Enter** to save.
11. Press the **Down** arrow - the screen will read “Primed Sensitivity”. Default is “1”.
12. Press **Select** to change the priming sensitivity. The cursor will highlight the number.
13. Use the **Up** or **Down** arrows to change from 1% to 100%. Increasing the number makes the Priming less sensitive.
14. Press **Enter** to save.
15. Press the **Down** arrow - the screen will read “Priming Delay”. Default is 20 seconds.
16. Press **Select** to change the priming delay time.
17. Use the **Up** or **Down** arrows to change from 1 second to 10 minutes.
Caution: Increasing the time causes the pump to stay in the priming mode longer.
18. Press **Enter** to save the setting.
19. Press **Escape** to exit.



Disabling Priming with an Automation System

When the IntelliFloXF® Variable Speed Pump is connected to an automation control system, (IntelliTouch®, EasyTouch® or SunTouch® Control Systems), **the priming feature on the pump cannot be disabled by the external automation control system only. It must also be disabled on the pump itself.**

If priming is enabled on start up, the pump responds to its internal settings *before* responding to commands from an automation control system.

If the pump is connected to an automation control system and priming is not desired, **disable the priming feature on both the pump and the automation control system.**

Refer back to page 14 for instructions on accessing the priming menu and features.

To disable priming with an automation system:

1. Disable the priming feature on the automation control system at the load center or using an IntelliTouch or EasyTouch system remote. (Refer to the automation control system user's guide for additional information).
2. Temporarily disconnect the RS-485 communication cable.
3. Open the lid to the control panel to disable priming on the pump. Press **Menu**, use the arrow buttons to scroll and select "Priming", then select "Disabled" (the factory default is set to "Enabled"). Press **Escape** to exit the menu.
4. Once priming is disabled, reinstall the RS-485 communication cable.

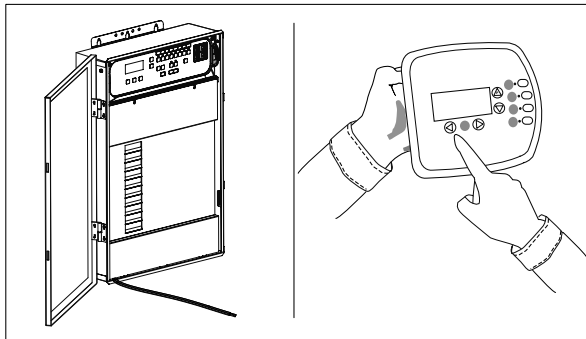

1. Disable priming on automation control system.

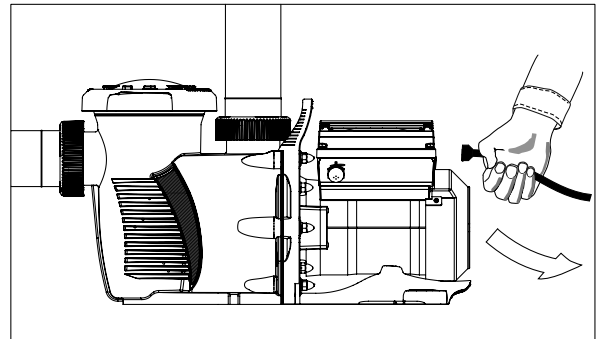

2. Disconnect the RS-485 communication cable.

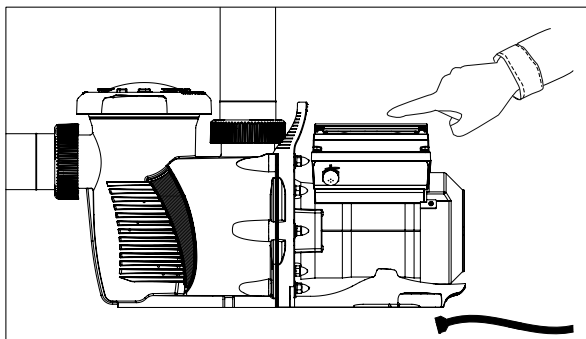

3. Disable priming on pump.

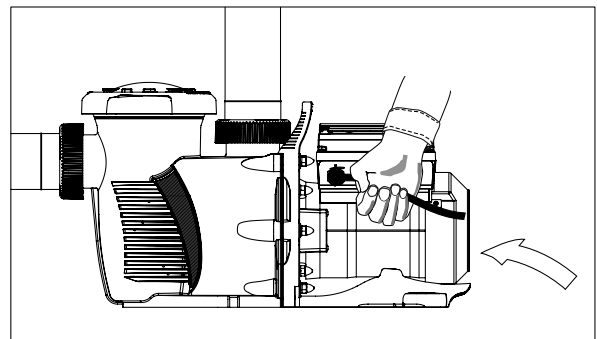

4. Reinstall the RS-485 communication cable.



The sensor for Anti Freeze is in the drive, on top of the motor. This feature allows you to set a speed (450 RPM - 3450 RPM) that runs when the IntelliFloXF® Variable Speed Pump goes into anti freeze mode. The temperature level that you wish anti freeze mode to start can also be set.

IMPORTANT NOTE: This feature is for protection of the pump. Do not depend on the anti freeze feature for freeze protection of the pool. Certain situations could cause the pump to sense a different temperature than actual air temperature.

Your automation systems air temperature sensor should be used to sense actual temperature. For example, if the pump is located indoors, the temperature of the room does not indicate the outdoor temperature. The pump does not sense the water temperature.

To access the Anti Freeze menu:

1. Check that the green power LED is on.
2. Press **Menu**.
3. Use the **Down** arrow to scroll to “Anti Freeze” and press **Select**.
4. The factory default for Anti Freeze is “Enabled“. To disable Anti Freeze, press **Select** to highlight “Enabled”.
5. Press the **Up** arrow - “Disabled” is displayed.
6. Press **Enter** to save.

To Set Anti Freeze Speed and Pump Temperature:

1. With Anti Freeze displayed on the screen, press the **Down** arrow - “Set Speed” is displayed. The factory default is 1000 RPM.
2. Press **Select** to change the speed. The cursor will highlight the first column (ones).
3. Use the **Up** or **Down** arrows to set speed (450 - 3450 RPM).
4. Press **Enter** to save the speed.
5. Press the **Down** arrow to Pump Temperature (the temperature the pump will activate AntiFreeze, default is 40° F/4.4° C).
6. Press **Select** to change the setting. The cursor will highlight the first column. Can be set 40° F to 50° F (4.4° C - 10° C).
7. Press **Enter** to save the temperature setting.
8. Press **Escape** to exit.

Note: To cancel any changes, press **Escape** to exit without saving.



Setting the Anti Freeze Pump Speed

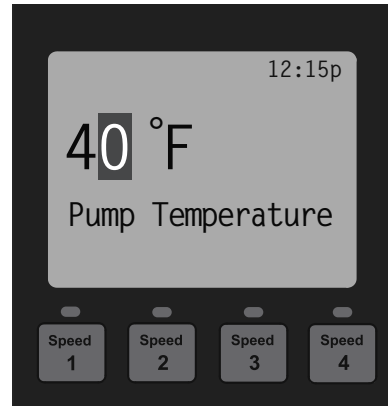

Setting the Anti Freeze Pump Temperature

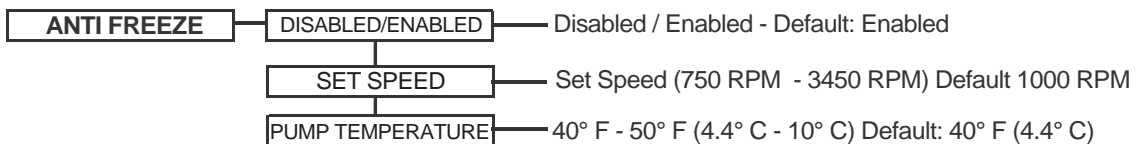

Anti Freeze Menu Options

CONNECTING TO AN AUTOMATION SYSTEM

External Control with IntelliComm® Communication Center

Use the RS-485 communications cable to remotely control the IntelliFloXF® Variable Speed Pump from an IntelliComm communication center. The IntelliComm communication center provides four (4) pairs of input terminal connections. These inputs are actuated by either 15 - 240 VAC or 15 - 100 VDC. Use the device inputs, to control the programmed pump speeds.

Note: For the pump to accept commands from the IntelliComm communication center, the pump must be in the “Running Schedules” mode (LED above Start/ Stop button is on). If more than one input is active, the highest number will be communicated to the pump. The IntelliComm communication center will always communicate to pump using ADDRESS #1.

Program Number Priority

If programs 1 and 2 are activated, program 2 will run, regardless of the assigned speed (RPM). The higher program number will always take priority.

Refer back to page 12 for instructions for setting up Programs in the External Control menu.

External Control is for programming speeds that will run when the IntelliComm communication center controller sends it a command.

For example, Terminal 3 and 4 in IntelliComm system will correspond to External Control Program #1. (5 and 6 to Ext Ctrl #2). Use the External Control feature to program the IntelliComm communication center.

Wiring Terminal Descriptions for IntelliComm Communication Center

Terminal Number	Terminal Name	Voltage	Max. Current	Phase Type	Frequency
1-2	Power Supply	100 - 240 VAC	100 mA	1 Input	50/60 Hz
3-4	Program 1	15 -240 VAC or 15 - 100 VDC	1 mA	1 Input	50/60 Hz
5-6	Program 2	15 -240 VAC or 15 - 100 VDC	1 mA	1 Input	50/60 Hz
7-8	Program 3	15 -240 VAC or 15 - 100 VDC	1 mA	1 Input	50/60 Hz
9-10	Program 4	15 -240 VAC or 15 - 100 VDC	1 mA	1 Input	50/60 Hz
11 12	RS-485 + Data: Yellow - Data: Green	-5 to +5 VDC	5 mA	1 Output	N/A
	 Ground				

Connecting to EasyTouch® and IntelliTouch® Control Systems

The pump can be controlled by an EasyTouch or IntelliTouch control system via the RS-485 communication cable. The EasyTouch and/or IntelliTouch control system starts, stops and controls the speed of the pump.

EasyTouch and/or IntelliTouch systems rewrite the pump memory when a command is given. This can take several seconds and can cause a delay until the pump physically responds.

The pump control panel is disabled when communicating with an EasyTouch and/or IntelliTouch system. **The EasyTouch and/or IntelliTouch system will not start communicating with the pump until the pump is assigned to a circuit.** The default pump address is “1” (only address for EasyTouch system).



IntelliComm Communication Center

See page 8 for details about how to check and or set the pump address. For more information, refer to the IntelliTouch (P/N 520100) or EasyTouch automation system User's Guide (P/N 520584).

Installation and User's Guides are available at: www.pentairpool.com/pool-owner/manuals.

To connect the IntelliFloXF® Variable Speed Pump communication cable to EasyTouch® or IntelliTouch® Control System load center:

1. Switch the main power off to the load center.
2. Unlatch the two enclosure door spring latch, and open the door.
3. Remove the two retaining screws securing the high voltage cover panel, and remove it from the enclosure.
4. Loosen the two access screws securing the control panel.
5. Lower down the hinged control panel to access the EasyTouch or IntelliTouch system circuit board.
6. Route the communication cable into the plastic grommet (located on the lower left side of the load center), up through the low voltage raceway to the EasyTouch or IntelliTouch system circuit board.
7. Strip back the cable conductors 6 mm (1/4"). Insert the two wires into the COM port screw terminals on the EasyTouch and/or IntelliTouch system circuit board. Secure the wires with the screws.
8. **EasyTouch COM port (J20):** Connect the GREEN (#2) and YELLOW (#3) wires to the COM port screw terminals (#2 and #3). Be sure to match the color coding of the wires; YELLOW to YELLOW and GREEN to GREEN. The Red wire is not connected. Secure the wires with the screws.

IntelliTouch COM port (J7/8): Connect the GREEN (#2) and YELLOW (#3) wires to the COM port (J20) screw terminals (#2 and #3). Be sure to match the color coding of the wires; YELLOW to YELLOW and GREEN to GREEN. The Red wire is not connected. Secure the wires with the screws.

Note: Multiple wires may be inserted into a single screw terminal.

9. Close the control panel into its original position and secure it with the two screws.
10. Install the high voltage cover panel and secure it with the two retaining screws.
11. Close the load center front door. Fasten the spring latch.
12. Switch the power on to the load center.

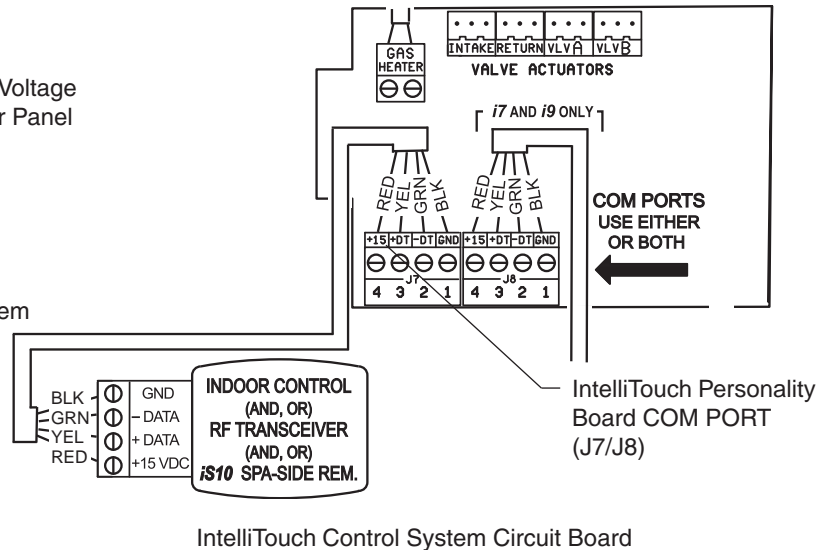
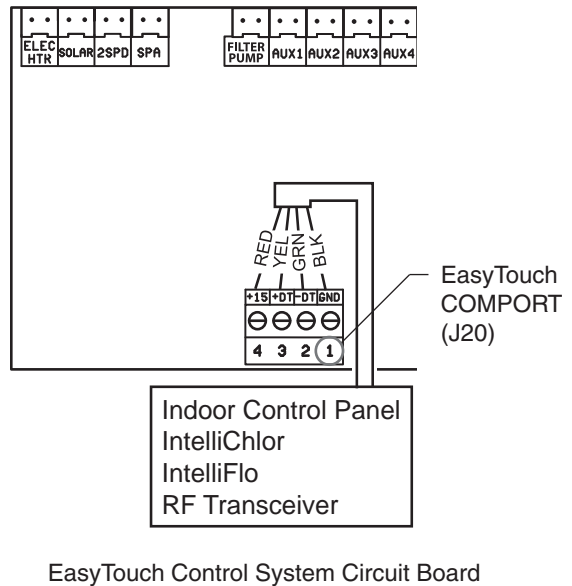
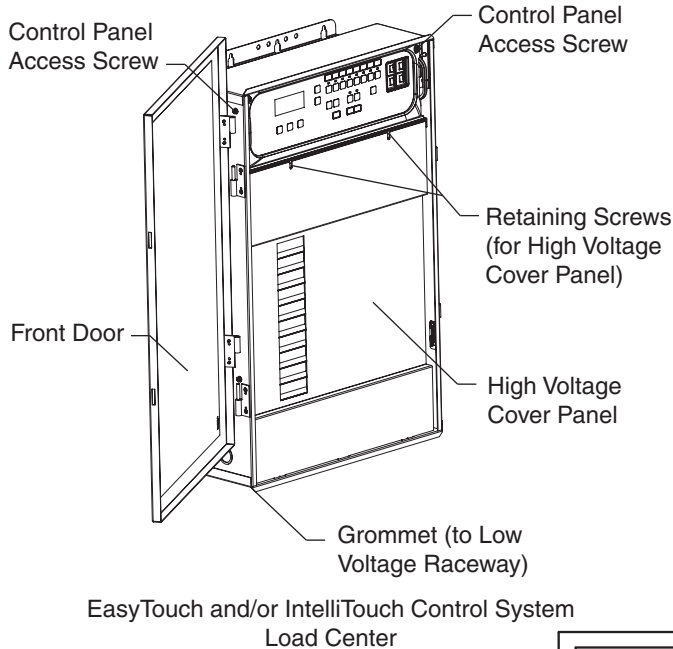

Connecting the Pump to a SunTouch® Control System

The IntelliFloXF® and IntelliProXF® Variable Speed Pumps can be controlled by a SunTouch control system via the RS-485 communication cable.

To connect the pump RS-485 communication cable to the SunTouch control system circuit board:

1. Unlatch the front door of the SunTouch system power center and open the door.
2. Loosen the retaining screw on front panel. Open the hinged front panel to access the electronics compartment.
3. Route the two conductor cable up through the power center grommet opening located on the left side, and up through the low voltage raceway to the motherboard.



WARNING Switch OFF main system power to the SunTouch system power center before making any connections.

4. Strip back the cable conductors 6 mm (1/4"). Insert the wires into the screw terminals (provided). Secure the wires with the screws. Be sure to match the color coding of the wires; YELLOW to YELLOW and GREEN to GREEN.
5. Insert the connector on the COMPORT (J11) screw terminal on the SunTouch system circuit board.
6. Close the control panel and secure it with the retaining screw.
7. Close the front door. Fasten the spring latch.

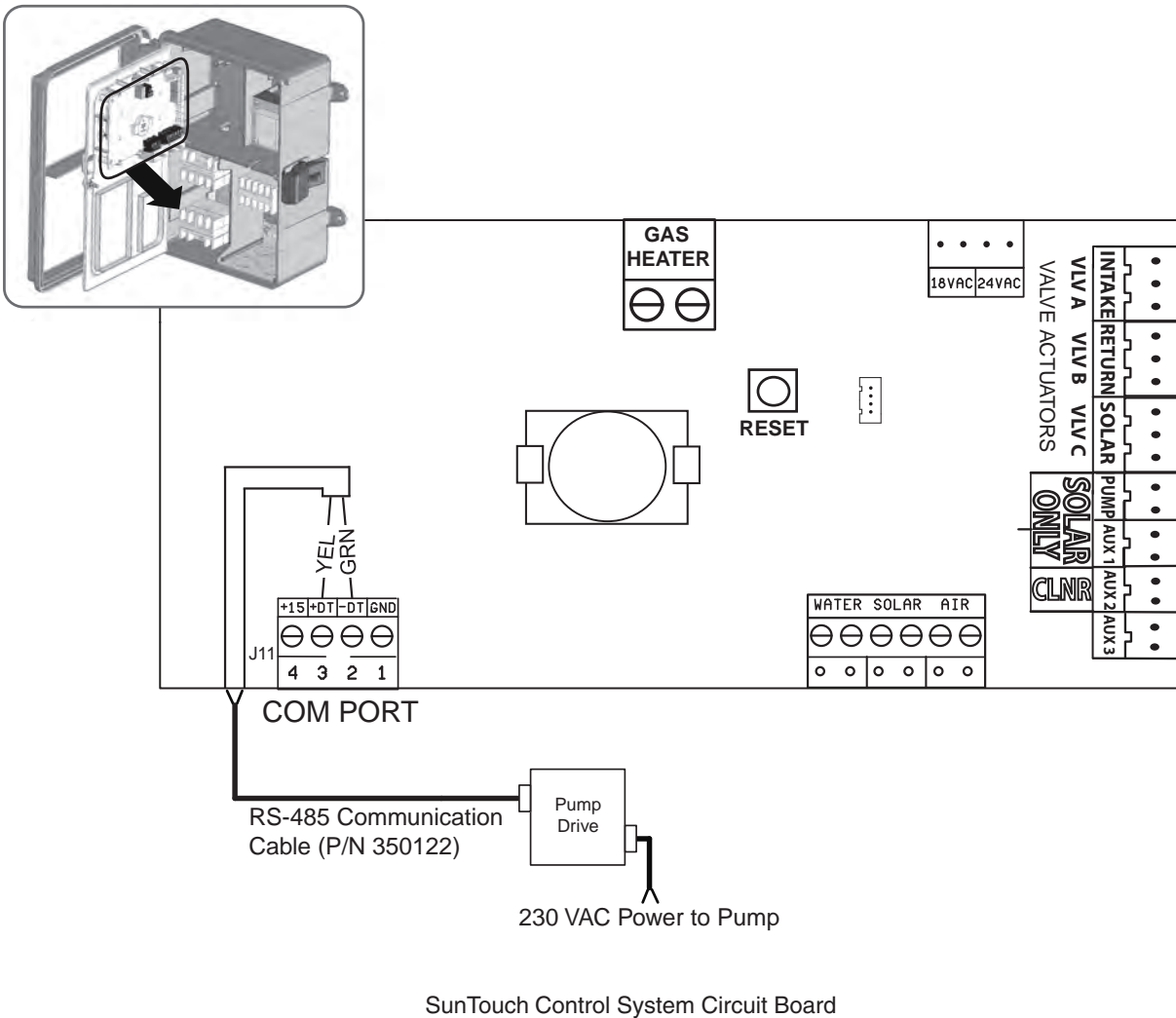

MAINTENANCE

⚠ WARNING

DO NOT open the strainer pot if pump fails to prime or if pump has been operating without water in the strainer pot. Pumps operated in these circumstances may experience a build up of vapor pressure and may contain scalding hot water. Opening the pump may cause serious personal injury. In order to avoid the possibility of personal injury, make sure the suction and discharge valves are open and strainer pot temperature is cool to touch, then open with extreme caution.

⚠ CAUTION

To prevent damage to the pump and for proper operation of the system, clean pump strainer and skimmer baskets regularly.

Pump Strainer Basket

The strainer basket (or 'strainer pot'), is located in front of the IntelliFloXF® Variable Speed Pump housing. The strainer basket must be kept clean and free of debris. Inspect basket through the lid on the top of the housing. Be sure to visually inspect the strainer basket at least once a week. Dirty strainer baskets reduce filter and heater efficiency and put abnormal stress on the pump motor.

Cleaning the Pump Strainer Basket

1. Press **Start/Stop** button on the pump and turn off the pump at the circuit breaker. Disconnect communication cable from pump.
2. Relieve pressure in the system.
3. Turn the lid and clamp counter-clockwise and remove from the pump.
4. Remove debris and rinse out the basket. Replace the basket if it is cracked.
5. Put the basket back into the housing. Be sure to align the notch in the bottom of the basket with the rib in the bottom of the volute.
6. Fill the pump pot and volute up to the inlet port with water.
7. Clean the lid and clamp, O-ring, and sealing surface of the pump pot.

Note: It is important to keep the lid O-ring clean and well lubricated.
8. Reinstall the lid by placing the clamp and lid on the pot. Be sure the lid O-ring is properly placed.

Seat the clamp and lid on the pump then turn clockwise until the locking ring handles are horizontal.
9. Turn the power "ON" at the circuit breaker. Reconnect communication cable from pump.
10. Open the manual air relief valve on the top of the filter. Stand clear of the filter.
11. Wait until all pressure is relieved. Start the pump.
12. Bleed air from the filter until a steady stream of water comes out of the filter air relief valve. Close the manual air relief valve.

⚠ WARNING

THIS SYSTEM OPERATES UNDER HIGH PRESSURE.

When any part of the circulating system (e.g., Lock Ring, Pump, Filter, Valves, etc.) is serviced, air can enter the system and become pressurized. Pressurized air can cause the lid to separate which can result in serious injury, death, or property damage.

To avoid this potential hazard, follow above instructions.



Winterizing

To protect the pump electronics from freeze damage, the pump will switch on to generate internal heat as the temperature drops below freezing. *The Anti Freeze feature is not intended to protect the system plumbing from freezing.*

- In mild climate areas, when temporary freezing conditions may occur, run your filtering equipment all night to prevent freezing.
- You are responsible for determining when freezing conditions may occur. If freezing conditions are expected, take the following steps to reduce the risk of freeze damage. **Freeze damage is not covered under warranty.**

To prevent freeze damage, follow the procedures below:

1. Shut off electrical power for the pump at the circuit breaker.
2. Drain the water out of the pump housing by removing the two thumb-twist drain plugs from the housing. Store the plugs in the pump basket.
3. Cover the motor to protect it from severe rain, snow and ice.

Note: Do not wrap motor with plastic or other air tight materials during winter storage. The motor may be covered during a storm, winter storage, etc., but never when operating or expecting operation.

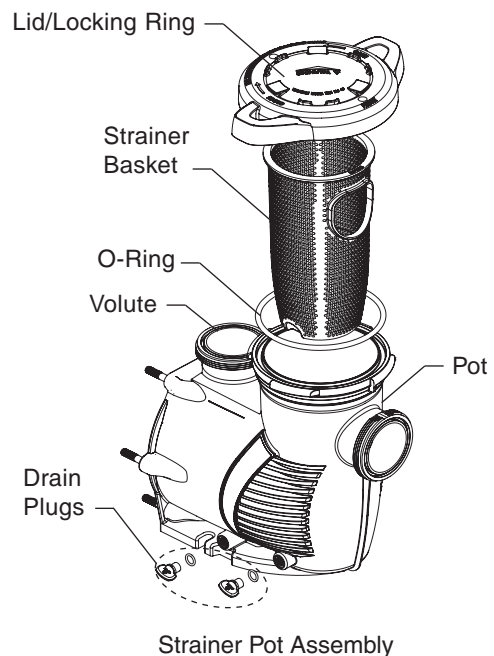

WARNING

Always disconnect power to the IntelliFloXF® Variable Speed Pump at the circuit breaker and disconnect the communication cable before servicing the pump. Failure to do so could result in death or serious injury to service people, users or others due to electric shock. Read all servicing instructions before working on the pump.

WARNING

DO NOT open the strainer pot if pump fails to prime or if pump has been operating without water in the strainer pot. Pumps operated in these circumstances may experience a build up of vapor pressure and may contain scalding hot water. Opening the pump may cause serious personal injury. In order to avoid the possibility of personal injury, make sure the suction and discharge valves are open and strainer pot temperature is cool to touch, then open with extreme caution.

CAUTION

Be sure not to scratch or mar the polished shaft seal faces; seal will leak if faces are damaged. The polished and lapped faces of the seal could be damaged if not handled with care.

Motor Care

Protect from heat

1. Shade the motor from the sun.
2. Any enclosure must be well ventilated to prevent overheating.
3. Provide ample cross ventilation.

Protect against dirt

1. Protect from any foreign matter.
2. Do not store (or spill) chemicals on or near the motor.
3. Avoid sweeping or stirring up dust near the motor while it is operating.
4. If a motor has been damaged by dirt it may void the motor warranty.
5. Clean the lid and locking ring O-ring, and sealing surface of the pump pot.

Protect against moisture

1. Protect from continuous splashing or continuous sprayed water.
2. Protect from extreme weather such as flooding.
3. If motor internals have become wet - let it dry before operating. Do not allow the pump to operate if it has been flooded.
4. If a motor has been damaged by water it may void the motor warranty.

The Mechanical Seal

The mechanical seal consists primarily of two parts, a rotating ceramic seal housed in the impeller and a stationary spring seal in the sealplate. The pump requires little or no service other than reasonable care. A mechanical seal may occasionally become damaged and must be replaced.

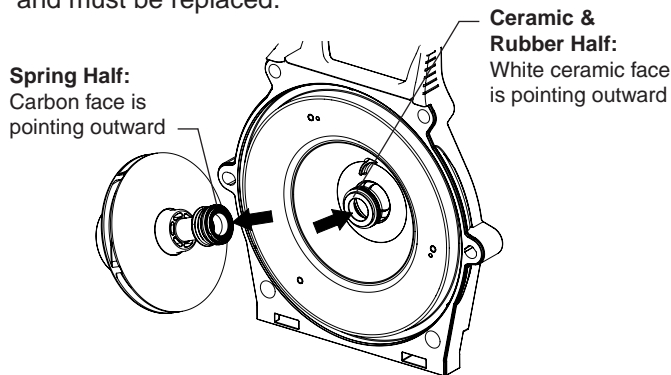

Mechanical Seal

Pump Disassembly

Tools required:

- Locking pliers
- Flat blade and Phillips head screwdriver
- 9/16 inch wrench
- 3/4 inch socket wrench
- 9/64 inch Hex key wrench

To remove and repair the motor subassembly, follow the steps below:

1. Turn off the pump circuit breaker at the main panel.
2. Drain the pump by removing the drain plugs.
3. Disconnect the RS-485 communication cable from the pump (if connected to pump).
4. Disconnect supply power in the field wiring compartment.
5. Remove (3) Phillips head screws from the top of the device located under the key pad cover.
6. Remove the drive by lifting upward to pull off the motor.
7. Using a 9/16 inch wrench, remove the six (6) nuts that secure the main pump body (strainer pot/volute) to the rear subassembly.
8. Gently pull the two pump halves apart, removing the rear subassembly.
9. Remove the three hex head screws holding the diffuser in position with a 9/64 inch hex key wrench
10. Hold the impeller securely in place by hand. Remove the impeller lock screw located at the center of the impeller. The screw is a left-handed thread and loosens in a clockwise direction. A deep well 3/4 inch socket and ratchet will fit the impeller screw. Remove the impeller screw o-ring. Inspect the o-ring for damage, cracks etc. Replace if damaged. Remove the (3) screws on the fan cover and remove fan cover.
11. Using locking pliers to hold the motor shaft, twist the impeller counter-clockwise to remove it from the shaft.
12. Remove the four (4) nuts from the seal plate to the motor using a 9/16 inch wrench.
13. Place the seal plate face down on a flat surface and press out the ceramic part of the mechanical seal.
14. Clean the seal plate, seal housing, and the motor shaft.

Pump illustrated parts view on the next page

Pump Reassembly/Seal Replacement

1. Install the **spring end** of the mechanical seal onto the impeller shaft. Be sure **black/carbon** face is facing outward.
2. Remount the seal plate to the motor using the four (4) lock washers and four (4) nuts.
3. With the white ceramic face facing outward, press the seal into the seal plate with your thumbs and wipe off the ceramic with a clean cloth. Do not lubricate seal faces.
4. Hand tighten impeller onto the motor shaft.
5. Screw in the impeller reverse lock screw (counter-clockwise to tighten).
6. Install the rear plastic cover on the back of the motor.
7. Remount the diffuser onto the seal plate. Make sure the plastic pins and holding screw inserts are aligned (see “TOP” indicator).
8. Assemble the motor subassembly to the housing. Do not tighten the nuts and washers until all four (4) motor bolts are in place. Using a torque wrench, install and tighten the four nuts to a torque value of 100 in-lbs (maximum). Do not overtighten the nuts.
9. Reinstall the drive onto the top of the motor.
10. Fill the IntelliFloXF® Variable Speed Pump with water.
11. Reinstall the pump lid and locking ring; see “Cleaning the Pump Strainer Basket” on page 20.
12. Prime the system. See page 4 for priming instructions.

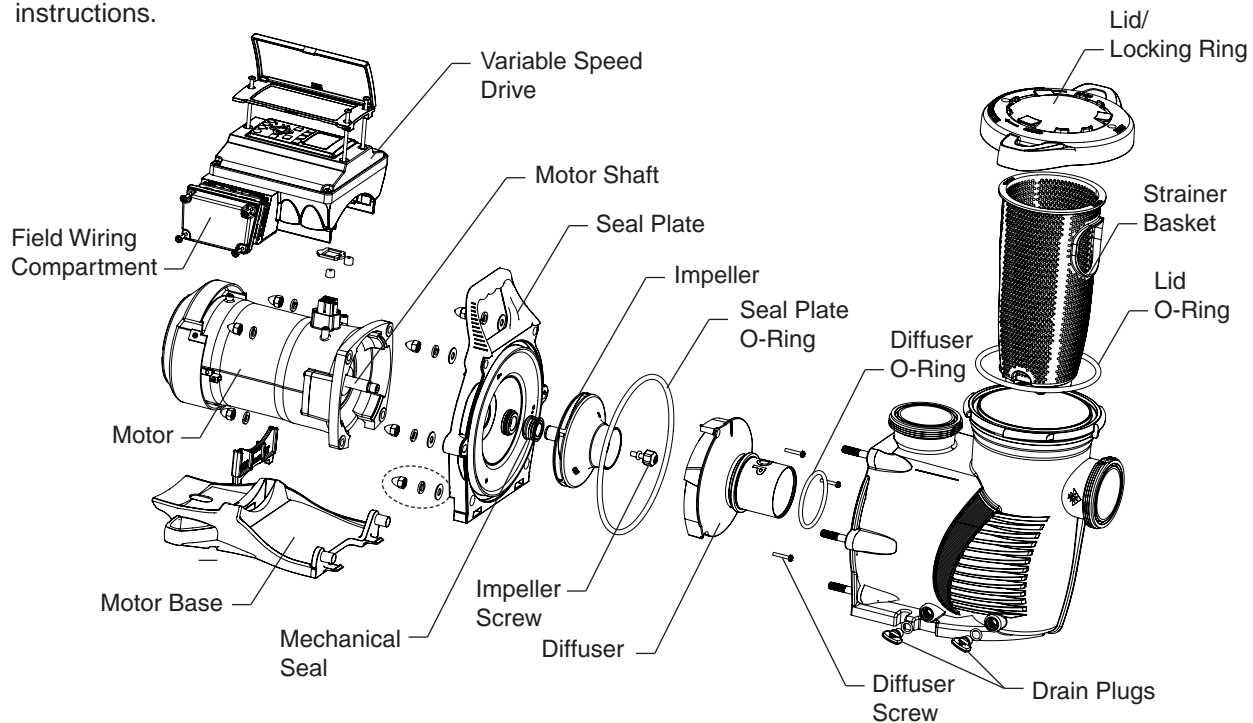

Pump Illustrated Parts View

Drive Assembly Removal and Installation



WARNING To avoid dangerous or fatal electrical shock hazard, switch OFF power to motor before working on pump or motor.



CAUTION To avoid electrical hazard, do not remove the four tamper proof screws from the motor assembly.

To remove the drive and control panel from the motor assembly:

1. Be sure all electrical breakers and switches are turned off before removing the drive.
2. Disconnect the RS-485 communication cable from the pump.
3. Open the control panel cover.
4. Remove the three Phillips head screws securing the drive to the motor assembly as shown.
5. Lift up the drive assembly and remove it from the motor adapter located on top of the motor assembly.

Note: Be careful not to remove the gasket between the drive and motor; it is critical in keeping moisture out of the drive and motor. Replace the gasket if damaged. Do not reassemble with a damaged or missing gasket.

Drive Assembly Removal and Installation

CAUTION

Before installing this product, read and follow all warning notices and instructions on pages ii - iii.

To install the drive assembly onto the motor assembly:

1. Be sure all electrical breakers and switches are turned off before installing the drive.
2. Be sure that the gasket between the drive and motor is in place. It is critical in keeping moisture out of the drive and motor. Replace the gasket if damaged. Do not reassemble with a damaged or missing gasket.
3. Verify that the three (3) orange motor post caps are in position before placing the drive on the motor assembly.
4. Align the drive assembly with the motor adapter and seat the drive on the motor assembly.
5. Secure and tighten the drive assembly with the three Phillips head screws.

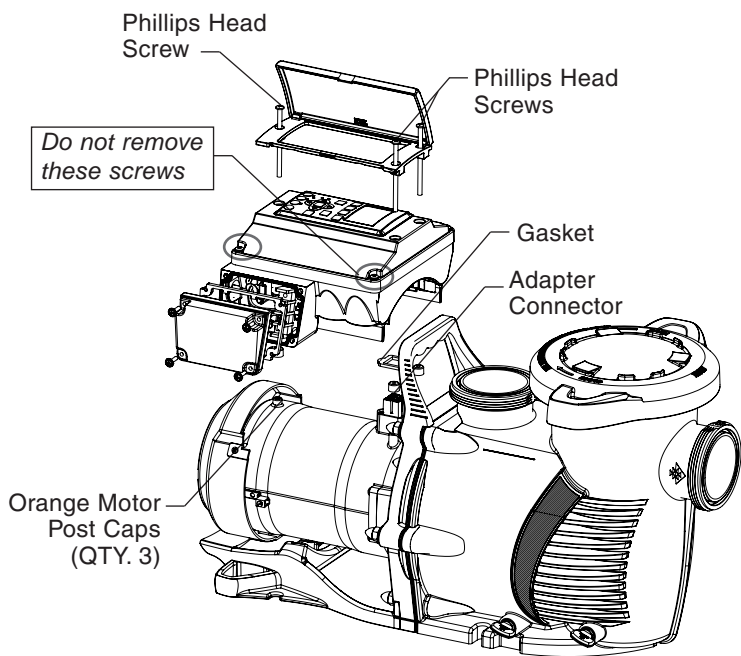

Drive Assembly and Removal

WARNING

FIRE and BURN HAZARD - The pump motor may run at a high temperatures. To reduce the risk of fire, do not allow leaves, debris, or foreign matter to collect around the pump motor. To avoid burns when handling the motor, shut off the motor and allow it to cool for 20 minutes before servicing. The pump provides an automatic internal cutoff switch to protect the motor from heat damage during operation.

Alerts and Warnings

The IntelliFloXF® Variable Speed Pump displays all alarms and warnings on the control panel display. When an alarm or warning condition exists, the corresponding light will be lit on the display.

All control panel buttons are disabled until the alarm or warning is acknowledged with the Enter button. Press the Reset button to clear the alarm once the fault condition has been resolved.

Note: The pump will not start if the impeller is rotating.

Power Out Failure

The incoming supply voltage is less than 170 VAC. The drive faults to protect itself from over current. The drive contains capacitors that keep it powered up long enough to save the current run parameters. If power is restored during this process, approximately 20 seconds, the drive will not restart until completed.

Priming Error

If the pump is not defined as primed within the “Max Priming Time” it will stop and generate a “Priming Alarm” for 10 minutes, then attempt to prime again. The “Max Priming Time” is set by the user on the priming menu as discussed on page 14. If the pump cannot prime within five attempts it will generate a permanent alarm that must be manually reset.

Overheat Alert

If the drive temperature gets above 54.4° C (130° F) the pump will slowly reduce speed until the over temperature condition clears.

Anti-Freezing

When active, the motor will run at the preset RPM until the drive temperature increases above the minimum. The pump’s internal antifreeze protection is disabled when connected to an automation system. Freeze protection is provided by selecting YES at the ON WITH FREEZE portion of the circuit function menu in the IntelliTouch® Control System. To re-enable the internal antifreeze protection, the power to the drive must be cycled off then back on. **Important: See explanation of Anti-Freeze mode on page 16.**

Over Current

Indicated that the drive is overloaded or the motor has an electrical problem. The drive will restart 20 seconds after the over current condition clears.

Over Voltage

Indicates excessive supply voltage or an external water source is causing the pump and motor to rotate thereby generating an excessive voltage on the drives internal DC buss. The drive will restart 20 seconds after the over voltage condition clears.

If restarting the pump after service or maintenance, please follow the priming instructions on page 4.

TROUBLESHOOTING

⚠ WARNING



Always disconnect power to the IntelliFloXF® Variable Speed Pump at the circuit breaker and disconnect the communication cable before servicing the pump. Failure to do so could result in death or serious injury to serviceman, pool users or others due to electric shock. DO NOT attempt to adjust or service without consulting your dealer or a qualified pool technician. Read the entire Installation & User's Guide before attempting to use, service, or adjust the pool filtering system or heater.

Problem	Possible Cause	Corrective Action
<p>Pump failure. (For alert display messages, refer to Alerts and Warnings on page 23).</p>	<p>Pump will not prime - Air leak in suction. PRIME ERROR may be displayed.</p> <p>Pump will not prime - Not enough water.</p> <p>Pump does not come out of prime.</p> <p>Pump stainer gasket is clogged.</p> <p>Pump strainer gasket is defective.</p>	<p>Check suction piping and valve glands on any suction gate valves. Secure lid on pump strainer pot and be sure lid gasket is in place. Check water level to be sure skimmer is not drawing air.</p> <p>Be sure the suction lines, pump, strainer, and pump volute are full of water.</p> <p>Adjust prime sensitivity to a higher setting (default setting is 1%).</p> <p>Clean pump strainer pot.</p> <p>Replace gasket.</p>
<p>Reduced capacity and/or head. (For alert display messages, refer to Alerts and Warnings on page 23).</p>	<p>Air pockets or leaks in suction line. PRIME ERROR may be displayed.</p> <p>Clogged impeller. PRIME ERROR may be displayed.</p> <p>Pump strainer pot clogged. PRIME ERROR may be displayed.</p>	<p>Check suction piping and valve glands on any suction gate valves.</p> <p>Turn off electrical power to the pump. Remove the (6) bolts that holds the housing (strainer pot/volute) to seal plate. Slide the motor and seal plate away from the volute.</p> <p>Clean debris from impeller. If debris cannot be removed, complete the following steps:</p> <ol style="list-style-type: none"> 1. Remove diffuser and o-ring. 2. Remove left hand thread anti-spin bolt and o-ring. 3. Remove, clean and reinstall impeller. 4. Reinstall anti-spin bolt and o-ring. <p>Reinstall diffuser, and o-ring.</p> <p>Reinstall motor and seal plate into volute.</p> <p>Reinstall clamp band around seal plate and volute and tighten securely. Clean suction trap.</p> <p>Clean pump strainer pot.</p>
<p>Pump trips and restarts constantly.</p>	<p>Air in system.</p> <p>Suction lift above design limits.</p> <p>Blocked suction Blocked discharge</p> <p>System flow too high. System changing flow too quickly. In floor cleaning system issues.</p> <p>Priming not enabled.</p> <p>Issues related to other equipment, such as Heat Pumps and Heaters with internal valves that vibrate.</p>	<p>Bleed air from filter. Be sure air bubbles are not visible coming into pump pot.</p> <p>Insert vacuum gauge into pump port connection port. Confirm vacuum level is 25 in. mercury (hg) or less.</p> <p>Stop pump and clear blockage.</p> <p>Reduce system flow. Change speed. Reduce water flow. In floor cleaning systems must be designed with balanced hydraulic losses on all legs.</p> <p>Enable priming from the "PRIMING" menu.</p> <p>Lowering ramp speed below 200 RPM may resolve the issue or addition of external manual valve controls, may resolve issue.</p>

Problem	Possible Cause	Corrective Action
<p>Inadequate circulation. (For alert display messages, refer to Alerts and Warning on page 23).</p>	<p>Filter or pump basket dirty.</p> <p>Suction/discharge piping is too small.</p> <p>Speed is set too slow for proper filtration cycle.</p>	<p>Check trap basket; if plugged, turn pump off and clean basket.</p> <p>Check and clean pool filter.</p> <p>Increase piping size.</p> <p>Increase filtration run time.</p>
<p>Electrical problem. (For alert display messages, refer to Alerts and Warning on page 23).</p>	<p>Could appear as a “Low Voltage” alarm. PRIME ERROR may be displayed.</p> <p>Could appear as “Over Heat” alert. PRIME ERROR may be displayed.</p>	<p>Check voltage at motor terminals and at panel while pump is running. If low, see wiring instructions or consult power company.</p> <p>Check for loose connections.</p> <p>Check line voltage; if less than 90% or more than 110% of rated voltage consult a licensed electrician.</p> <p>Increase ventilation.</p> <p>Reduce ambient temperature.</p> <p>Tighten any loose wiring connections.</p> <p>Motor internal terminal overload protector is open.</p> <p>Motor runs too hot. Turn power to motor off.</p> <p>Check for proper voltage.</p> <p>Check for proper impeller or impeller rubbing.</p>
<p>Mechanical Troubles and Noise.</p>	<p>The pump motor is running but with loud noise.</p> <p>Foreign matter (gravel, metal, etc.) in pump impeller.</p> <p>Cavitation.</p>	<p>If suction and discharge piping are not adequately supported, pump assembly will be strained. Do not mount pump on a wooden platform! Securely mount on concrete platform for quietest performance.</p> <p>Disassemble pump, clean impeller, follow pump service instructions for reassembly.</p> <p>Improve suction conditions.</p> <p>Increase pipe size.</p> <p>Decrease number of fittings.</p> <p>Increase discharge pressure.</p>
<p>Pump does not respond to IntelliTouch, EasyTouch, SunTouch, IntelliComm system commands.</p>	<p>Improper automation setup.</p> <p>Communication network inoperative.</p>	<ol style="list-style-type: none"> 1. Be sure that the communication cable is connected at both ends. 2. Check that the pump local address matches with the address used in the IntelliTouch control system. 3. Check that the pump has been assigned a circuit name on the IntelliTouch control system. 4. Ensure that the pump display says “DISPLAY NOT ACTIVE”. <p>A defective device on the network can inhibit the proper operation of other network device. Devices should be disconnected sequentially until the network starts working.</p>

REPLACEMENT PARTS

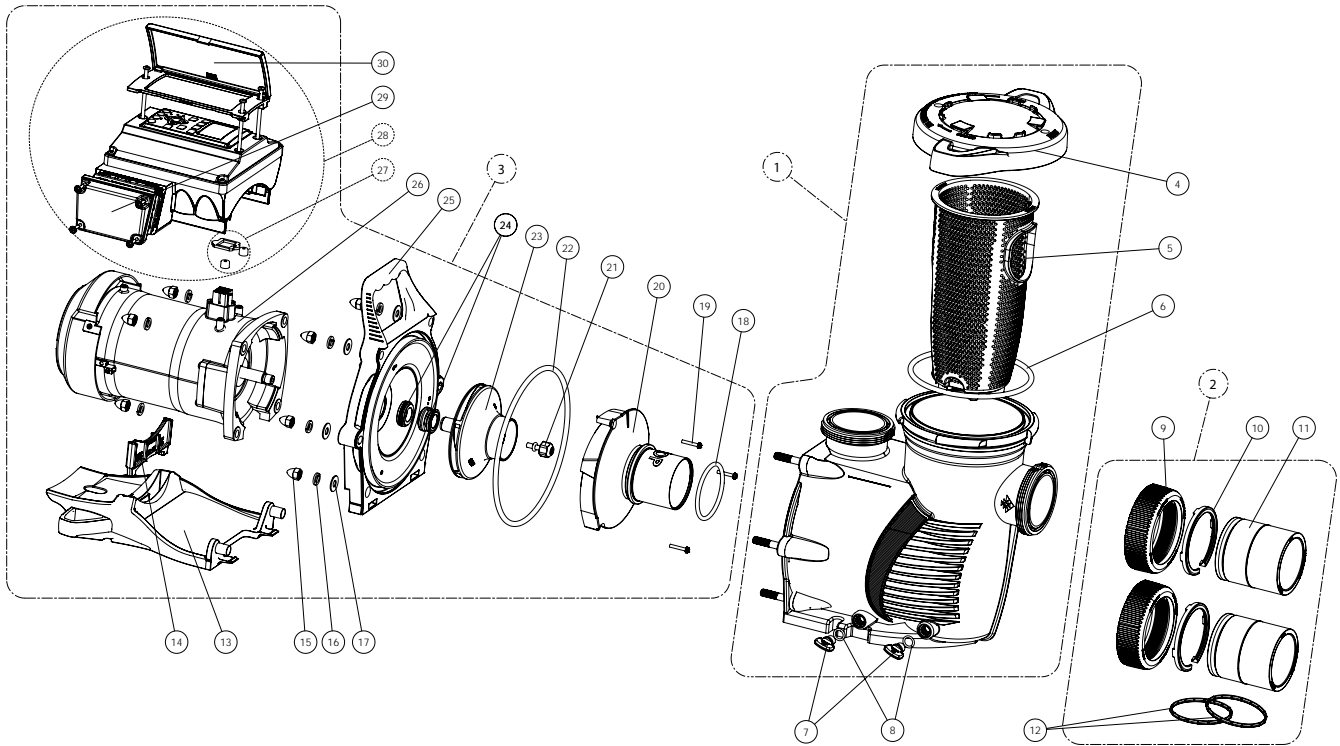

IntelliFloXF® and IntelliProXF® Variable Speed Pump Replacement Parts

Item No.	Description	IntelliFloXF	IntelliProXF
1	Wet End Assembly	400000	401000
2	Union Kit Without Tap	410020	
3	Power End Assy. w/ Drive	400605	401605
4	Lid/Locking Ring Assy. - Black	400006	401006
5	XF Replacement Basket	400007z	
6	Lid/Locking Ring O-Ring	35505-1440	
7	Drain Plug	071131	357161
8	Drain Plug O-Ring	192115	
9	2.5" Union Nut	411000	
10	2.5" C-Clip Locking Ring	410001	
11	2.5" Union Adapter w/o Tap	410002	
12	2.5" Diamond Seal Kit (Includes two)	410016z	
13	Motor Base	400004z	401004z
14	Motor Support Insert	070429	
15	Acorn Nut	071413	
16	Split Lock Washer	U43-12SS	
17	Flat Washer	072184	
18	Diffuser O-Ring	350336	

Item No.	Description	IntelliFloXF	IntelliProXF
19	Diffuser Screw	353323	
20	Diffuser	400010	
21	Impeller Reverse Screw	37337-6080	
22	Seal Plate O-Ring	351446	
23	Impeller Assembly	400015	
24	Mechanical Seal Assembly	37400-0028s	
25	Seal Plate	400002	401002
26	Motor Kit	350105s	357294s
27	Drive Hardware and Gasket Kit	350612	
28	Variable Spd Drive Assy. Kit	353251	353252
29	Field Wiring Comp Kit w/ Gasket	350621	353310
30	Control Cover Assy. Kit	350601	350701
Not Shown	Riser Plate XF to Challenger	400012	
Not Shown	Seal Plate Kit With Mech Seal	400031z	400032z
Not Shown	Hardware and O-Ring Kit	400030z	

Pump Performance Curves

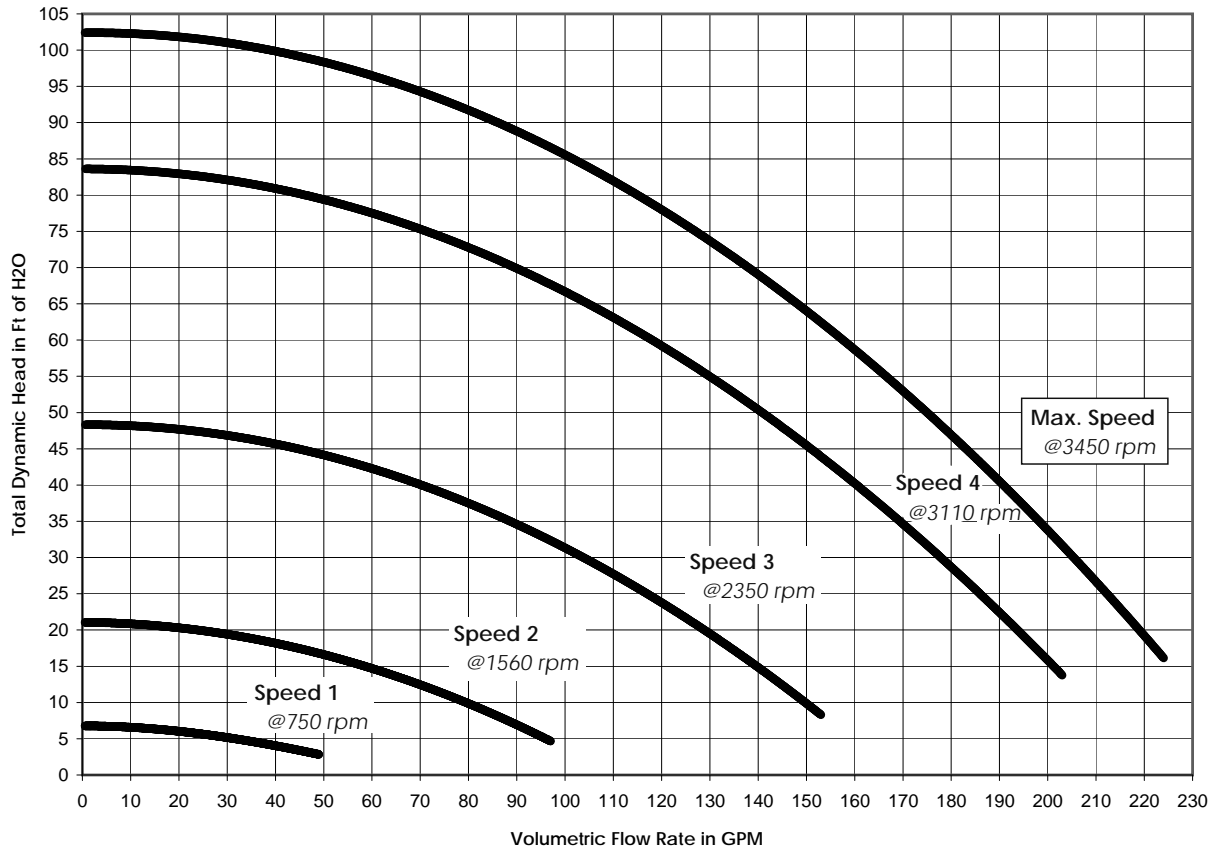

Pump Dimensions

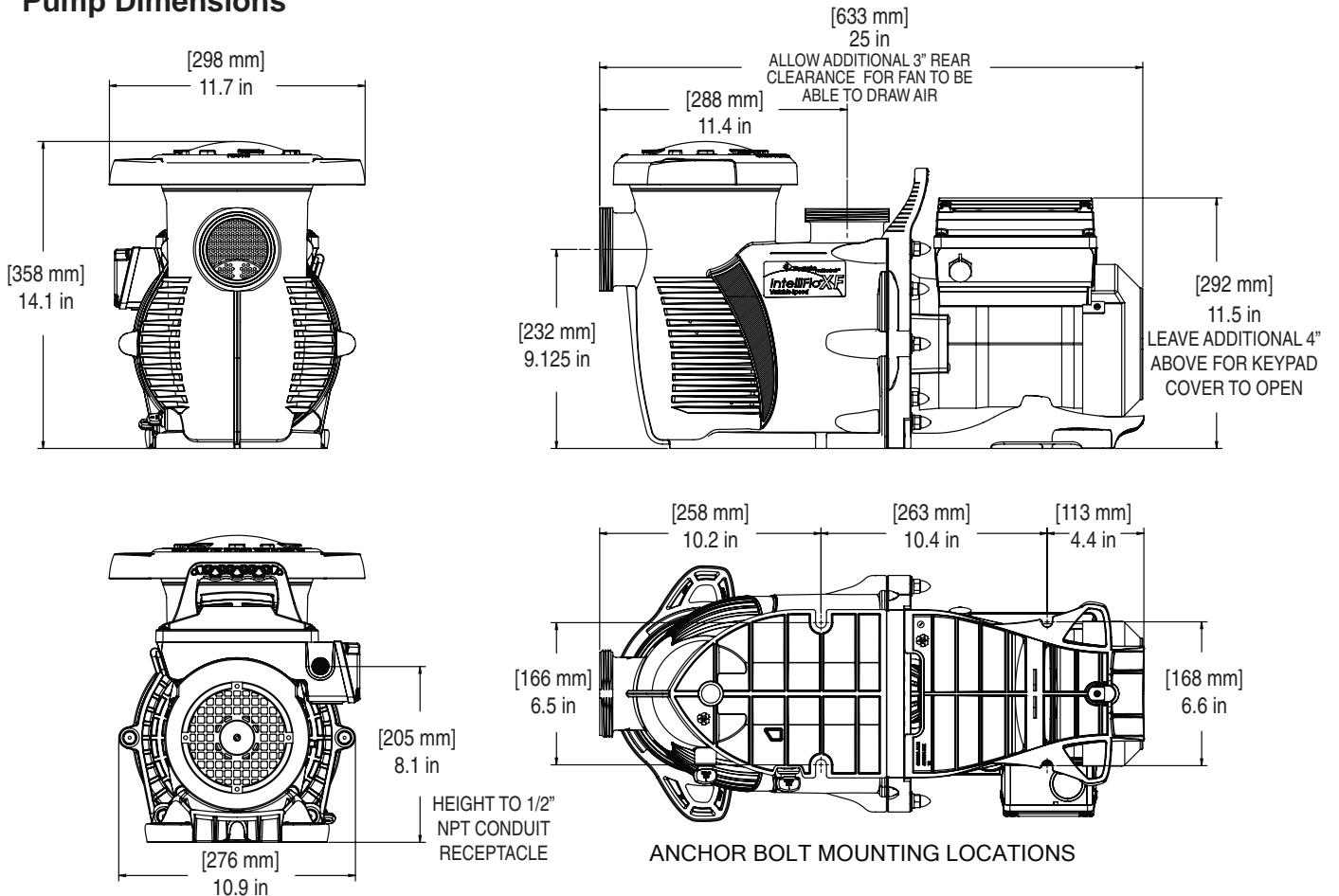

Operator Control Panel: Pump Menu Quick Reference Guide

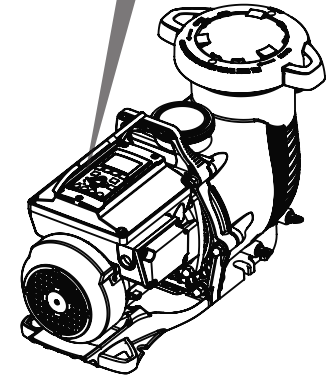
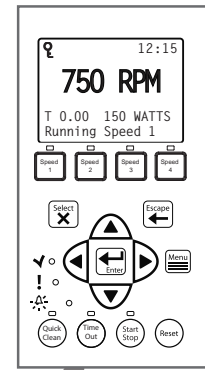
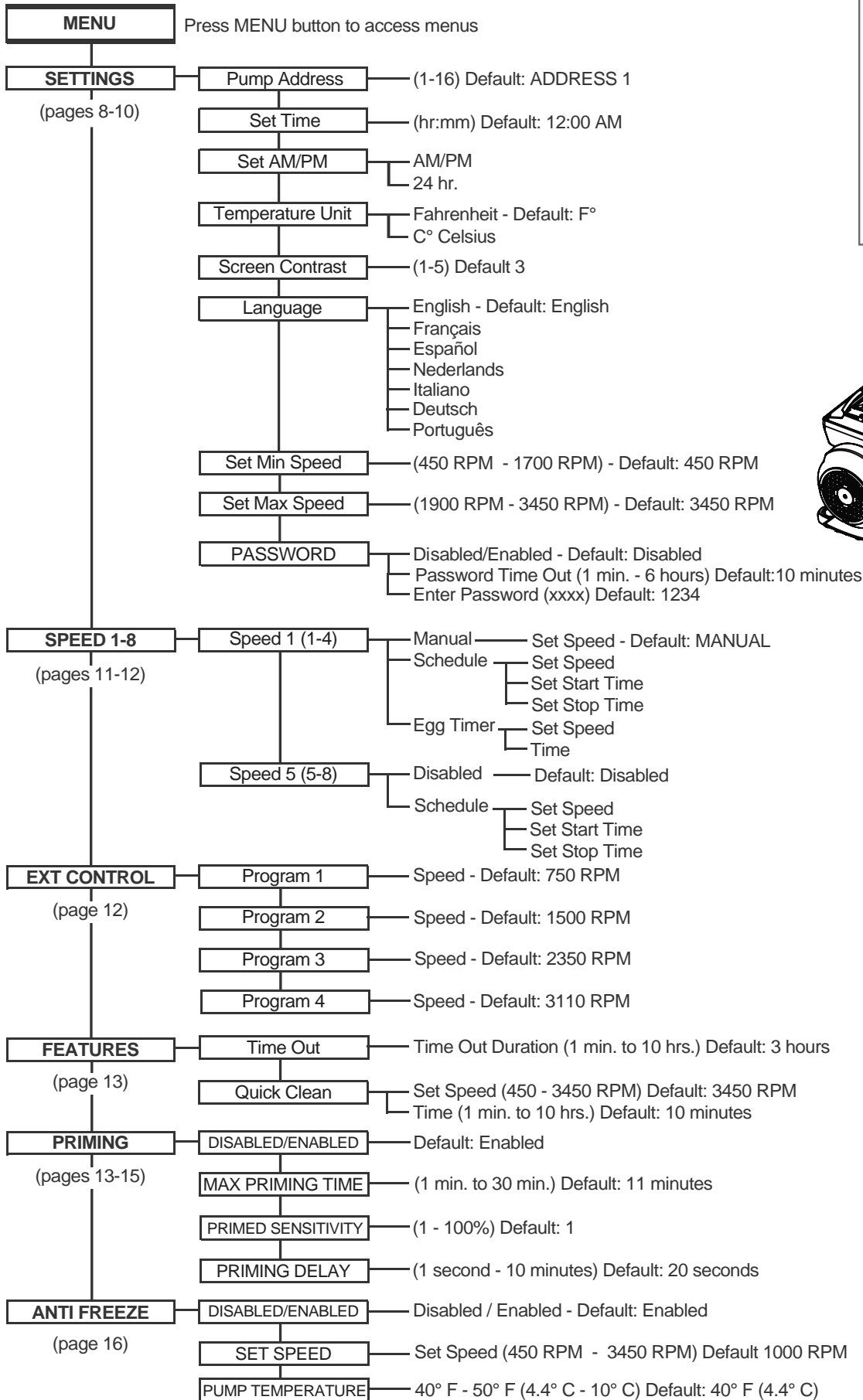



LIT. PKG. P/N 353062



1620 HAWKINS AVE., SANFORD, NC 27330 • (919) 566-8000
10951 WEST LOS ANGELES AVE., MOORPARK, CA 93021 • (805) 553-5000
WWW.PENTAIRPOOL.COM

All Pentair trademarks and logos are owned by Pentair, Inc. Pentair Aquatic Systems™, Sta-Rite®, IntelliFloXF®, IntelliProXF®, IntelliComm®, EasyTouch®, IntelliTouch®, SunTouch® and Eco Select® are trademarks and/or registered trademarks of Pentair Water Pool and Spa, Inc. and/or its affiliated companies in the United States and/or other countries. Unless expressly noted, names and brands of third parties that may be used in this document are not used to indicate an affiliation or endorsement between the owners of these names and brands and Pentair Water Pool and Spa, Inc. Those names and brands may be the trademarks or registered trademarks of those third parties. Because we are continuously improving our products and services, Pentair reserves the right to change specifications without prior notice. Pentair is an equal opportunity employer.

© 2013 Pentair Water Pool and Spa, Inc. All rights reserved. This document is subject to change without notice.



P/N 353061 REV. C 12/2/13