



PANTERA[®]

POOL PUMPS

HIGH PERFORMANCE PUMPS WITH 5 LEVELS OF CORROSION RESISTANCE.

With over 30 years experience selling into the pool industry, we know the more protection you give the motor, the better off you are and that's why we build five levels of motor protection into the Pantera range of pool pumps.



PENTAIRPOOL.COM.AU

KEY FEATURES

- 5 levels of corrosion resistance - Standard industry practice to protect pool pump motors from water ingress is normally only on two levels, a mechanical seal and flinger shaft sleeve.
- Elevated motor foot - Incorporating an elevated mount into the pump design keeps moisture well away from the motor.
- Shaft Sleeve - A nylon soft sleeve incorporating a flinger, adds additional water ingress protection.
- Self aligning barrel unions (40mm/50mm) included.
- Mechanical Seal - A heavy-duty 3/4" 316 Stainless Steel mechanical seal (on all models) provides extended life and longer intervals between servicing.
- Plastic Yoke and Lip-Seal - The wet end design integrates a moulded end-shield cover and lip seal, protecting the motor from water damage.
- 3 year limited warranty*.



*Terms & conditions apply.

MATERIALS

COMPONENT	MATERIAL
Pump casing:	20% Glass filled ABS
Impeller:	20% Glass filled ABS
Baffle:	20% Glass filled ABS
Diffuser:	20% Glass filled ABS
Yoke:	20% Glass filled ABS
Drain cap:	Polypropylene
Shaft sleeve:	Nylon
Motor shaft:	Nylon
End shield:	Cast iron
Hair and lint pot O-ring:	Nitrile Teflon
Casing O-ring:	Nitrile
Barrel union O-ring:	Nitrile
Barrel union:	ABS
Hair and lint pot lid:	Polycarbonate
Cord/ plug:	H07RNF 3G 1.0mm

MOTOR

Type:	TEFC 2 pole continuously rated
Nominal speed:	2800rpm
IP rating:	IPX5
Insulation class:	Class F
Thermal overload:	On-winding auto reset
Frequency:	50Hz
Voltage:	230-240V

PERFORMANCE CURVES

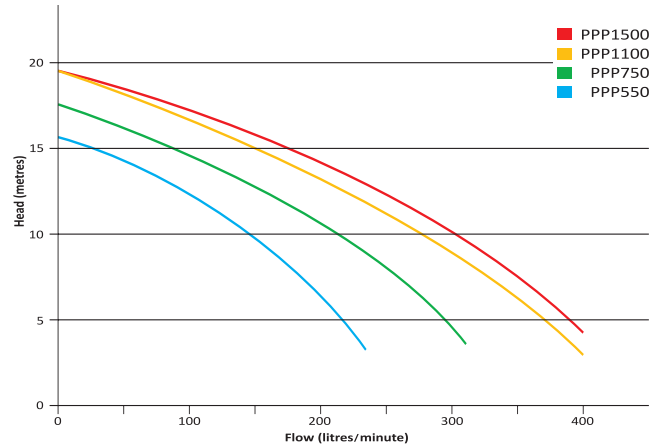

DIMENSIONS

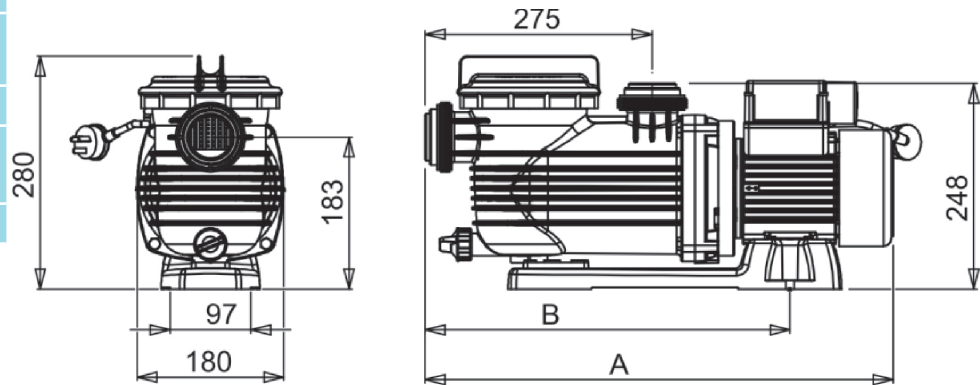

PUMP MODEL	PPP-550-1P	PPP-750-1P	PPP-1100-1P	PPP-1500-1P
A (mm)	565	565	602	602
B (mm)	428	428	465	465

MODEL DATA

Pump Model	Motor Kw Nominal	Supply Voltage	Phase	Full Load Current	Locked Rotor Current	Capacitor mfd	Sound Power Level	Supply Cord Length	Net Weight	Packed Weight	Carton Dimensions L x W x H
	kW(hp)			(A)	(A)		dBA*	(m)	(kg)	(kg)	(mm)
PPP-550-1P	0.55(3/4)	230-240V	1	2.9A	17A	20	62	2	12.5	14	660 x 240 x 305
PPP-750-1P	0.75(1)	230-240V	1	3.9A	17A	20	66	2	12.5	14	660 x 240 x 305
PPP-1100-1P	1.0(1 1/4)	230-240V	1	5.0A	21A	25	65	2	13.5	15	660 x 240 x 305
PPP-1500-1P	1.2(1 1/2)	230-240V	1	6.1A	21A	25	66	2	13.5	15	660 x 240 x 305



1-21 Monash Drive | Dandenong South, VIC 3175 | Australia | 1300 137 344 | pentairpool.com.au

Unless otherwise indicated, copyright in the content of this document is the property of Pentair Water Australia under Australian copyright law. Unless otherwise indicated, content may not be reproduced or transmitted without our prior written permission.