



FREEFLO

SALT CHLORINATOR

Owner's Manual



FFCL-15-RP0
FFCL-25-RP0
FFCL-35-RP0

PENTAIR ONGA FREEFLO SALT CHLORINATOR

Foreword

Congratulations on purchasing a Pentair Onga FREEFLO Salt Chlorinator for your swimming pool. This system is designed for robust reliability and easy operation to give you many years of trouble free service.

Please read the instructions thoroughly before operating your unit. If you have any concerns or require any further assistance, then please do not hesitate to contact our friendly staff or any of our Pentair distributors.

Chemicals

It is important to note that the Pentair Onga FREEFLO Salt Chlorinator does not maintain the water chemistry of your swimming pool water; it simply produces chlorine from a mild salt solution. To ensure that your chemical balances are within the guidelines listed below you should also have your water tested regularly at your local pool shop to encourage a sparkling clean healthy pool.

PH	7.2 – 7.4
Total Alkalinity	90ppm – 150ppm
Cyanuric Acid	40ppm – 65ppm
Salt	4000ppm
Chlorine	1.5ppm – 2.0ppm

For the best chlorine results in a balanced pool a salt level of 4000 parts per million (ppm) is required. This is easily achieved by using the formula below or approximately 20kg of salt per every 5000 litres.

For example:

Pool volume = Length x Width x Average Depth x 1000
= 9m x 4m x 1.5m x 1000
= 54000 litres

Salt required = Pool Volume x 4 (salt level required, 4000ppm)
1000
= 54000 x 4 / 1000 = 216kg
Or 11 x 20kg bags of pool salt

NB: Before adding salt to your swimming pool, please make sure your Pentair Onga FREEFLO Salt Chlorinator is switched off to avoid overload damage. **THIS WILL VOID ALL WARRANTY.** It is recommended to manually add chlorine to your swimming pool on initial startup as a Salt Chlorinator is designed to maintain chlorine levels and not run for unnecessary long hours to try to build an acceptable chlorine level. The manual addition of chlorine may also be required for unforeseen situations where your swimming pool has required a high chlorine demand, for example after large bather load.

TABLE OF CONTENTS

	Page
FREEFLO Salt Chlorinator Overview	2
Cell Housing Installation	
Installation No Heater	4
Installation With Heater	5
Installation With Solar	5
Installation With Automation - Single Speed Pump	6
Installation With Automation - Intelliflo Variable Speed Pump	6
Power Pack Installation	7
Functions	7
Time Settings	8
Maintenance	8
Troubleshooting	9
Spare Parts	10
Warranty	11



CELL HOUSING INSTALLATION

The electrolytic cell housing must be plumbed into the return line after the filter. Please see the installation diagram, fig.1, below for the preferred method. If a heater is plumbed into the system then the cell housing must be installed after the heater in the return line with a check-valve between the heater and the chlorinator to protect the elements or heat exchanger. If a solar heating system is installed then the cell housing should be fitted after the line going up to the roof and after the return line coming back from the roof if it rejoins the main swimming pool return. The cell housing has allocations for either 40mm PVC pipe or 50mm PVC pipe with the use of the supplied PVC reducing bushes.

-- Please note the installation position of the electrolytic cell for water probe positioning --

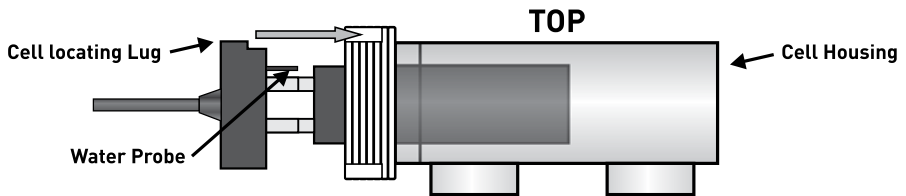

Installation No Heater

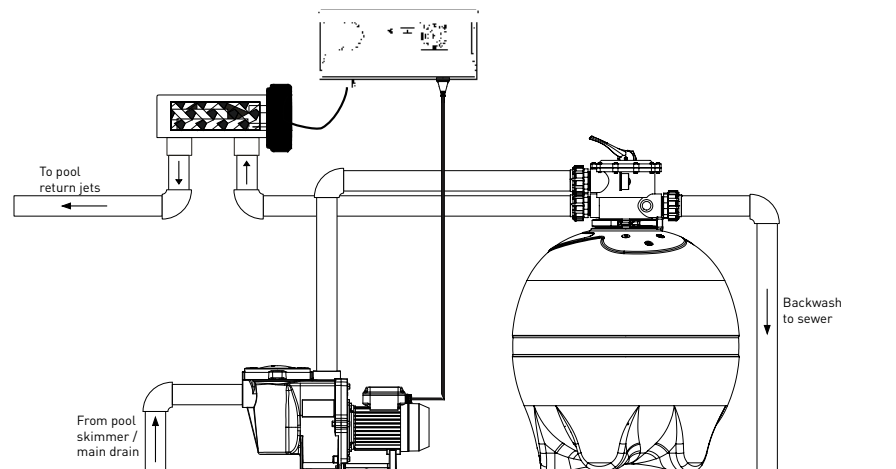

Installation With Heater

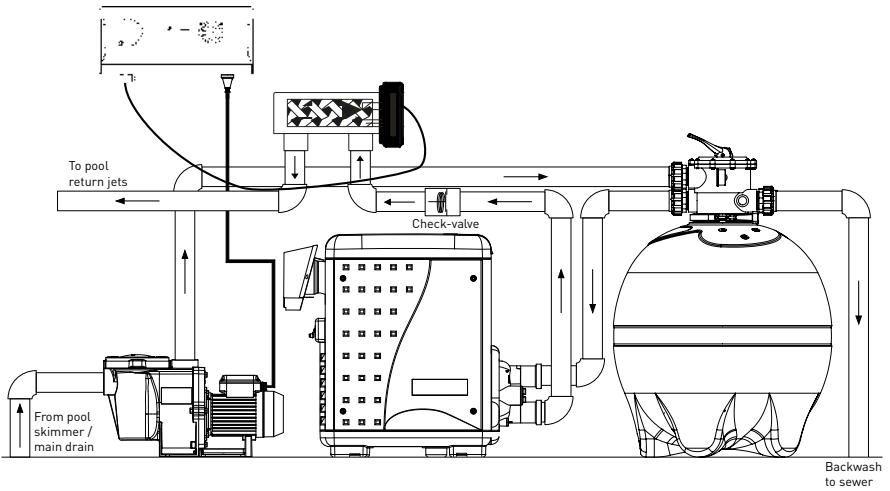

Installation With Solar

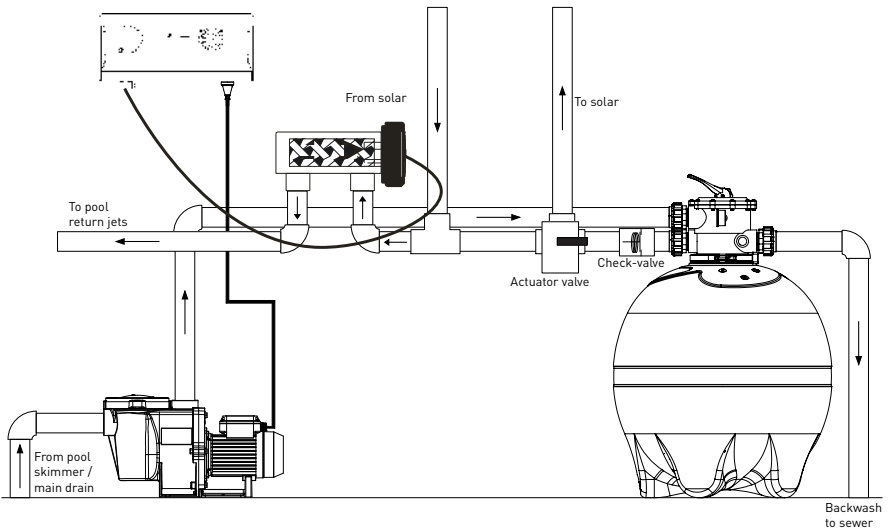

Installation With Automation - Single Speed Pump

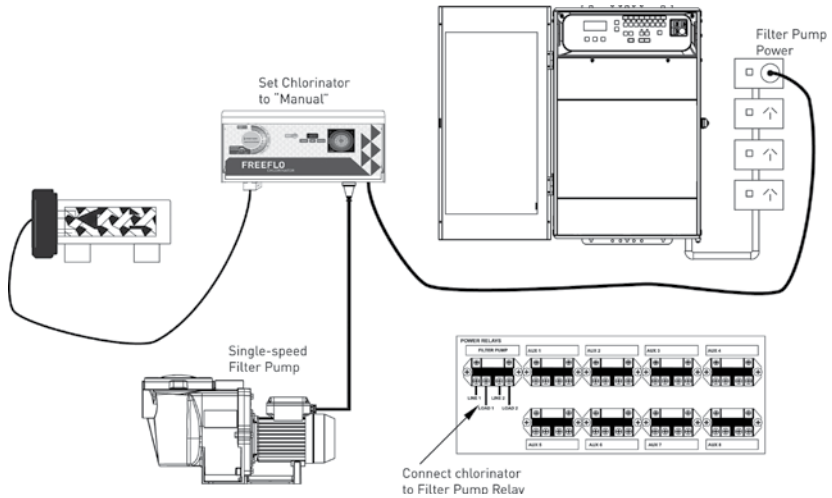

Installation With Automation - IntelliFlo Variable Speed Pump

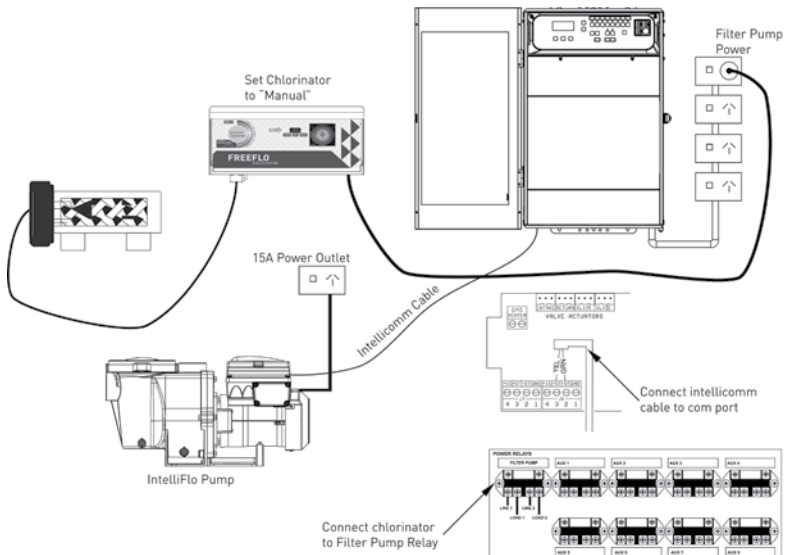

POWER PACK INSTALLATION

Mounting the Pentair Onga FREEFLO Chlorinator power pack is done by either using the supplied mounting bracket or directly hanging on the wall with screws. If mounting directly on the wall, use the guide notches on the top vents to position the holes for installation. The chlorinator power pack is to be mounted at least 800mm above ground level.

It is strongly recommended that the unit be installed where it is protected from the elements. Rain and sunlight will prematurely age your unit. It should also be mounted in a position where it is away from accidental water spray. The unit should be installed so that adequate air flow can circulate freely around the power pack to allow the chimney drafting effect to perform efficiently.

FUNCTIONS

All Pentair Onga FREEFLO Chlorinators are fitted with a 240v 10A power socket located on the right hand underside of the power pack. Your pool pump should be plugged into this socket so that the chlorinator and pump activate together when the timer switches on at the allocated time settings or in a model without a timer the pump and chlorinator is controlled by the on/off switch. (7 in fig 2). Failure to plug the pool pump into this socket could lead to the chlorinator staying on with no water circulation. In case of water probe failure, over heating and a possible gas build up may occur. Please see fig.2 below in regards to function control.

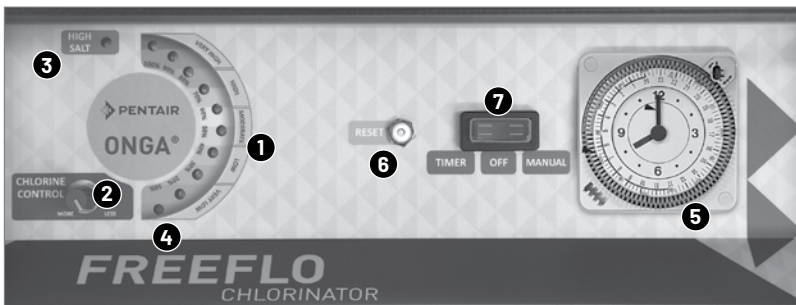

Fig.2

1. Chlorine Output LEDs - Fig.2: If the correct salt level is in the pool then all 10 lights will illuminate. Each light represents 10% chlorine output. If all lights are not illuminated then a higher salt level will be required. Make sure all salt is dissolved properly before adding more. The chlorine control, (2 in fig. 2), will increase or decrease the chlorine output to suit your chlorine demand. If all of the indicator lights flash then there is a water fault problem.

2. Chlorine Control - Fig. 2: The chlorine controller determines the amount of chlorine production. By simply turning the control anti-clockwise you increase the chlorine output and by turning the control clockwise you reduce the chlorine output. Do not force the control past its stop as this will damage the unit and void warranty.

3. High Salt Light - Fig. 2: This light is a red warning indicator and will only illuminate when the salt level in the swimming pool is higher than 4500 parts per million. If this light is on, decrease the output by turning the chlorine control, (2 in fig.2), clockwise until the high salt (red light) goes off and the 10 chlorine output LEDs are on (1 in fig 2). If this light is the only one illuminated then the unit has gone into over temperature cutout and will reset once back to normal running temperature.

4. Polarity Light - Fig. 2: The polarity light is the first indicator light, 10% in the chlorine output array, (4 in fig.2). This light will alternate between orange and green every reversing cycle, 4-12 hours. Factory setting is a 12 hour cycle.

5. Timer - Fig. 2: The time clock is designed for control of the chlorinator and circulation pump.

TIME SETTINGS

To set the time, turn the minute hand clockwise until the time of day is set on the Inner Dial. For example, to adjust the time to 8:00pm, adjust the Timer as per Fig 3. The Outer Dial has 24-hour markings with 15-minute increments to match the Inner Dial time at the Activation Point. It is important to ensure that if the time is set to 8.00pm, the Activation Point on the Outer Dial will align with 20, not 8, which would be 8.00am.

Program the Timer by pushing the captive trippers to the outer position for the entire period that the chlorinator and pump are to be turned "ON". Each tripper corresponds to 15 minutes on the 24-hour dial. When the tripper is pushed inwards, the Timer is in the "OFF" position.

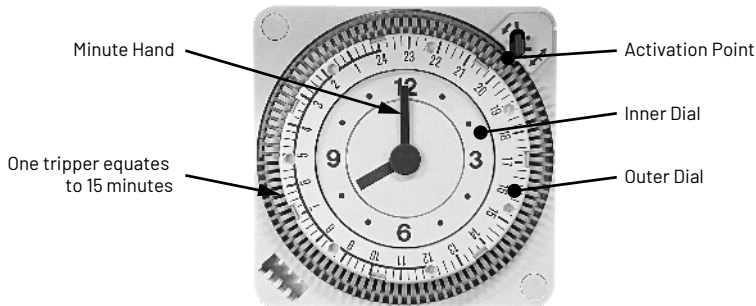

Fig.3

6. Circuit Breaker: A circuit breaker is mounted on the front of the Pentair Onga FREEFLO Chlorinator and is designed to activate in the event of power surge or overload. When activated the yellow centre button will pop out turning off the unit. To reset, press the yellow centre button back in to resume normal function. **Important note, turn off the chlorinator at the power point before attempting to reset the circuit breaker. Should the circuit breaker continually activate then you should contact your local Pentair distributor.**

7. Timer/Off /Manual Switch: This switch allows you to choose the timer operation mode for your chlorinator and pool pump. Switched to the left position, Timer, allows the chlorinator and pool pump to turn off and on at your designated timer settings. The Manual selection, switched to the right, allows the chlorinator and pump to work continuously until you physically change the chlorinator's mode. The Off position in the middle will turn the power off to the chlorinator and circulation pump.

MAINTENANCE

Correct pool water chemistry is important and regular testing should be carried out. In areas where pool water quality is poor some calcium build up may occur on the cell plates. This may require periodical cleaning in a mild hydrochloric acid solution. For more details contact your local pool shop or pool maintenance technician.

When cleaning the cell you must turn the chlorinator off or it will damage your unit and void warranty. Do not use any utensils or harsh chemical cleaners to remove any calcium buildup from the cell as it will damage the cell's semi precious coating and void warranty.

The chlorinator power pack should only be serviced by qualified electrical technicians. For your nearest Pentair recommended service technician, please contact us (see contact details at the back page of this manual).

TROUBLESHOOTING

FAULT / PROBLEM	POSSIBLE CAUSE	REMEDY
No flow. All chlorine output LED's flashing as per page 4, note1.	Pump turned Off.	Ensure pump is turned ON.
	Closed valve.	Open valve.
	Air in system.	Check all O-rings & grease.
	Dirty filter.	Clean or backwash filter.
	Low water level.	Fill up pool.
	Calcium build-up on water probe sensor.	Clean probe in a mild hydrochloric acid- ref. page 4.
High Salt Red LED illuminated.	Salt level too high, above 4500ppm.	Turn chlorine control clockwise as per page 7 note 2, until salt levels reduce. Comment: This remedy does NOT reduce the salt levels in the pool water, it reduces the chlorine output of the chlorinator to protect it.
No lights.	Circuit Breaker tripped. Page 3. Fig.6	Reset Circuit Breaker as per page 8, note 6.
	Mains power failure.	Check switches and switchboard circuit breaker.
Low / No chlorine production.	Chlorine output too low.	Increase chlorine production as per page 7, note 2.
	Salt level too low.	Increase salt level to 4000ppm and check stabiliser (Cyanuric) levels.
	PH too high.	Adjust PH between 7.2-7.4
	Timer period too short.	Increase running time.
	High phosphate levels.	Add starver.
	Cell connection.	Check connection at the junction box on the underside of the unit.
Abnormal calcium build-up in cell.	Calcium levels in swimming pool water extremely high or water chemistry.	Reduce calcium level in pool. Lower water level and fill with clean water. Use a calcium reduction agent. Clean cell with mild HCl solution.
Timer times-out of sync.	Timer not set correctly.	Check setting procedure as per page 7, note 5.
	Chlorinator installed on off-peak tariff.	Timer will need battery backup if installed on off tariff.
	Timer / Off / Manual switch not switched correctly.	Make sure switch is selected as per page 8, note 7.
Over temperature Red LED only.	Salt too high, above 4500ppm.	Turn chlorine control clockwise as per page 7, note 2. until salt levels (no other lights) reduce. Comment: This remedy does NOT reduce the salt levels in the pool water, it reduces the chlorine output of the chlorinator to protect it.
	Installed in an area where the ambient temperature is extremely high.	Supply adequate cooling. Install outside of the extreme temperature area.

SPARE PARTS

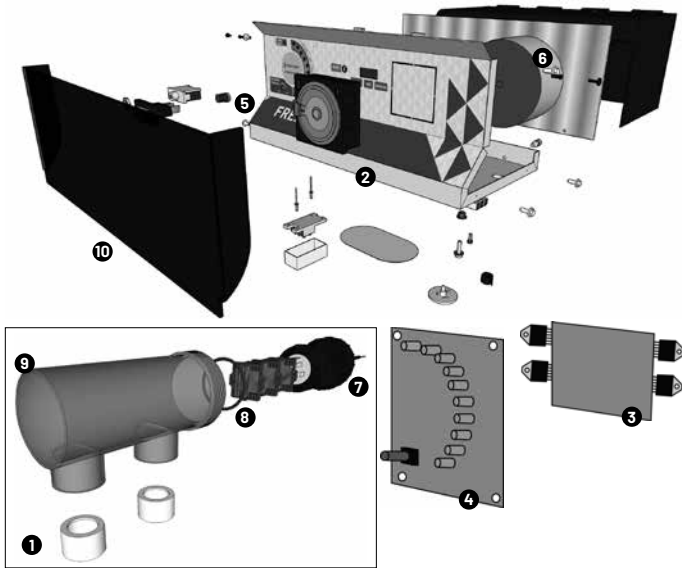

NO.	PART NO.	QTY.	DESCRIPTION
1	801933		Replacement Cell 15g
1	801934		Replacement Cell 25g
1	801935		Replacement Cell 35g
2	801936		Time Clock
3	801937		Power PCB Kit
4	801938		Control PCB Kit
5	801939		Control PCB Knob
6	801940		Transformer
7	801941		Cell Lock Nut
8	801942		O-ring Cell Union
9	801943		Cell Casing
10	801944		Perspex Cover

WARRANTY

Your Pentair Onga FREEFLO Chlorinator is covered by a 3 year warranty on the power pack and a 5 year pro-rata warranty on the cell from the date of purchase. The power pack controller and electrolytic cell are covered against defects in materials and assembly from the date of purchase in a domestic application. Warranty will not be given without proof of purchase, so keep your original purchase invoice in a safe place.

Unfavourable environments and operating conditions beyond the control of the manufacturer such as incorrect power supply (must be 230V 50 Hz), the Pentair Onga FREEFLO Chlorinator plugged into an ancillary device such as a Variable Frequency Drive, wear and tear, water and insect damage, extreme ambient temperatures or any other adverse situation that affects the Pentair FREEFLO Chlorinator will void warranty. All warranties only apply if the equipment is installed and operated in complete compliance with the installation and operating instructions.

Pentair Onga FREEFLO Chlorinators and electrolytic cells installed in a commercial situation are covered by a 1 year warranty. Commercial situations meaning motels/hotels, health spas, apartment/town house complexes and any situation with an unusually high bather load or abnormal conditions.

Pentair Australia will not accept liability for any consequential loss or damage of any kind.

FOR ALL WARRANTY ENQUIRIES, PLEASE CALL 1300 137 344.

IMPORTANT

Please attach your sales invoice/docket here as proof of purchase should warranty service be required. Please do not return warranty form to Pentair Australia. Retain for your records.

PURCHASED FROM:
PURCHASE DATE:
SERIAL NO:
MODEL NO:



1-21 Monash Drive | Dandenong South, VIC 3175 | Australia | 1300 137 344 | pentairpool.com.au

Information contained here-in remains the property of Pentair under Australian copyright law.
Content may not be reproduced or transmitted without our prior written permission.

Disclaimer: Pentair reserves the right to change product specifications and products details.
Product images are for reference purposes only and may not represent the actual/current product.

©2022 Pentair. All rights reserved.